



Practical Clock and Watch Servicing

Distance Learning Course

Technician Grade

Lesson 1

BRITISH HOROLOGICAL INSTITUTE
Upton Hall
Upton
Newark
Nottinghamshire
NG23 5TE
United Kingdom

First published in Great Britain
in 2011 by the British Horological Institute

Copyright © British Horological Institute 2011

Major contributors:

Stephen Robert Thackery
David John Poole, FBHI

This book is sold subject to the condition that the original purchaser will not copy, circulate, lend, give or sell this book to anyone else without the written consent of the publisher.

Founded in 1858, the British Horological Institute is the professional body for clock and watch makers and repairers in the UK. It provides information, education, professional standards and support to its members around the world.

Website:	http://www.bhi.co.uk
Email:	clocks@bhi.co.uk
Telephone:	(+44) (0)1636 813795
Fax:	(+44) (0)1636 812258

Contents

Overview.....	3
1 A brief history of timekeeping	5
2 Types of clocks and watches	6
3 Is time smooth?	28
4 The oscillator as a timekeeper	29
5 Basic divisions of a mechanical movement.....	30
6 A hands-on look at a simple clock.....	34
7 Health and Safety.....	49
8 Some common workshop tools	51
9 Introduction to Practical Exercises	75
10 The fundamentals of practical work	76
11 Hand removing levers	77

Overview

This first lesson covers a lot of ground; we shall start looking at a basic clock and tools which you will be using; watches will follow in Lesson 2. However, do not worry if you cannot remember all of it – we will look at all the technical content in more detail as we go through the rest of the course, and you will be able to refer back to this lesson whenever you wish.

Do make sure you have read the Introduction document, because that gives a lot of information on how to set up your workshop.

Knowledge and Understanding

The word "clock" comes from the Late or Medieval Latin word clocca, which means "bell".

1 A brief history of timekeeping

It is likely that Man first needed to keep time around 9000 years ago, with the invention of agriculture. Of course, predicting the right time to plant crops is much less demanding than arriving at a train station on time, and early Man almost certainly did not require timekeeping instruments, relying instead on observing and recording the cycles of the sun and moon.

As civilisation became more sophisticated, timekeeping became more important, and the first timekeeping instruments were developed. These were used in secular life, as well as in religious institutions to manage regular periods of worship. By modern standards their timekeepers were still very crude and inexact; they included candles and incense sticks which burned at a known rate. Sundials, which allow the passage of the sun to be accurately indicated, date back to around 3,500BC. The clepsydra, which works by the flow of water through a small hole, dates to around the 16th Century BC.

By the 14th Century AD mechanical clocks were being made in a form which would be familiar to us today. The first such clocks did not display the time, but simply rang bells to call people to worship. Over the following centuries, the developing sciences (such as astronomy) drove the need for ever more accurate clocks. The invention of the pendulum clock by Christiaan Huygens in 1656 led to a massive improvement in timekeeping accuracy.

Accurate timekeeping is essential for the navigation of ships, but a pendulum is quite unsuitable for use at sea due to the movement of the ship. It was not until 1773, a century after the pendulum clock had been invented, that John Harrison was recognised for producing a watch incorporating a balance that would keep time accurately enough for navigation at sea. Figure 1 shows a 20th century marine chronometer mounted in gimbals in a protective box.

The Industrial Revolution drove the need for public timekeeping. Factory workers had their daily schedules dictated by the unvarying beats of the machinery they tended. Few ordinary people could afford their own clock, so most factories and public buildings had large clocks on display, and factories would sound sirens to call the workers for the next shift.

The development of the railway network in the 18th and 19th Centuries required a sophisticated system of management based upon complex timetables. Accurate timekeepers (Figure 2) were essential for the railway operators, and a major asset for the travelling public.

The need for accurate timekeeping has invaded almost every aspect of modern life, and especially the sciences. Massive leaps in timekeeping accuracy were made in the 20th Century. The 1920s saw the invention of the quartz oscillator, which is still the most ubiquitous timekeeper in use today, and, arguably, marks the point at which the science of timekeeping was taken from horologists by physicists.



Figure 1 – marine chronometer



Figure 2 – American railroad watch

The most accurate timekeepers currently in use are known as “atomic clocks”. At their heart is a caesium resonator, accurate to less than one billionth of a second per day.

John Harrison would be impressed were he alive today. The caesium timekeepers used by the present-day Global Positioning System (GPS) allow anyone to pinpoint their position to within 20m or so, anywhere on the globe, using low cost shop-bought navigation aids. Sophisticated enhancements and error correction techniques provide positioning to within a few centimetres.

2 Types of clocks and watches

Bearing in mind how many centuries we have been making clocks, it is no surprise that there are countless different types. In this section we will look at some of the more common types you may come across.

Note: we have deliberately not used photographs of pristine clocks; many of the clocks you work on will be in average or poor condition.

2.1 Lantern clock

The lantern clock was introduced into Britain and Europe around 1620, and fell from popularity in the first half of the 18th century. The properties of the pendulum were discovered by Galileo in 1581 and early lantern clocks, which had only one hand, were made before the invention of the pendulum clock in 1656: they used balance wheels and kept fairly poor time.

The pendulum offered much better timekeeping, so clockmakers quickly adopted it, and many of the original lantern clocks were converted to use a pendulum.

Despite their improved accuracy, they were still made with just an hour hand, presumably for reasons of style and tradition.

Original lantern clocks from the era mentioned were all weight driven. Occasionally a spring-driven lantern clock may be found, but it will be either a modified weight-driven clock or a more modern reproduction.

The style of the lantern clock is very popular, and it enjoyed a resurgence of interest in the Victorian era. For this reason many clocks have been made in the style of the lantern clock, including modern quartz clocks.



Figure 3 – lantern clock

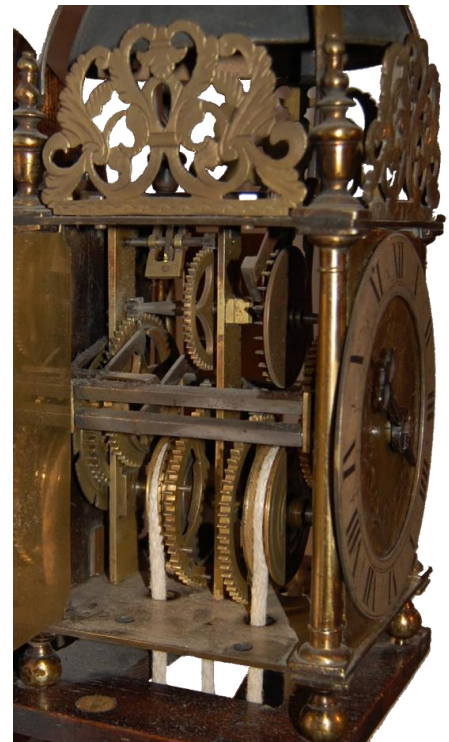

Figure 4 – lantern clock mechanism (modified to pin wheel escapement)

Due to their great age, and the fact that many were modified to improve their performance, it is very rare to find a fully original lantern clock. Lantern clocks are historically important and valuable, so you should take advice from an experienced professional before working on one.

The origin of the name “lantern clock” is uncertain. One theory is that the shape resembles a lantern of that historical period. Another theory is that it is a corruption of *latten*, which is a term used around that time for brass, i.e. a *brass clock*.

2.2 Bracket clock (sometimes known as a “spring clock”)

Figure 5 shows a typical 18th century bracket clock (this one was made around 1730). The two key holes in the dial indicate that it has two trains: a timekeeping train (known as the “going” train) and the striking train (clocks which chime use a third train). The movement is of good quality and beautifully engraved. The bell at the top of the movement is used to sound the hours, and you can see the hammer to the right of it. The pendulum is shown in its hold-fast, which is used when the clock is carried from room to room. The cord visible in the left photograph operates the repeat mechanism, which makes the clock strike the most recent hour again. This clock was made before electric or gas lighting so night-times were often pitch dark, making it impossible to read the time. The repeat cord lets the user know the time to within an hour.



Figure 5 – bracket clock



Figure 6 – bracket clock, showing beautiful engraving on back plate

The term *bracket clock* was first used for weight-driven clocks, which had to be mounted on a wall bracket to provide room for their weights to drop. Spring driven clocks like the one shown here continued to be made in the same style, and are often still referred to as bracket clocks, even though they are normally placed on a table. They are also sometimes called “spring clocks”.

2.3 Longcase clock

Longcase clocks are tall, weight driven pendulum clocks. They evolved from the lantern clock, the first ones essentially being lantern clocks with a case built around them.

There are two basic types of longcase: the 30 hour clock, which is wound by pulling on a rope to lift the weight, and the 8 day clock, which is key-wound through a hole in the dial. The 30 hour clock was aimed at the lower cost end of the market.



Figure 7 – a typical 8-day longcase clock

Most longcase clocks were made between the late 17th century and the second half of the 19th century, although clocks outside those dates can sometimes be found and they are still being made in small quantities to this day. Most strike the hours on a bell, and some have additional features such as a date or moon phase display.

Due to their historical interest and impressive appearance they are highly collectable. Interestingly, few of them have any great horological merit; they were conservative in their technology and did not generally employ the latest technical advances available at the time of manufacture. Robustness and reliability were more important. Nevertheless, due to their high value and historical importance the approach to servicing should be considered carefully.

The longcase is not to be confused with the “regulator” clock. There is sometimes a superficial resemblance, but regulator clocks used the most advanced techniques available at the time to achieve the highest possible timekeeping accuracy. Such techniques include the use of sophisticated escapements, and pendulums compensated for changes in temperature and barometric pressure. Regulators are exceptionally valuable and you should not work on one until you are fully competent.

Most, but not all, longcase movements were made in a few cities around Great Britain. They were shipped around the country to the provincial makers for final finishing and installation in the clock case.



Figure 8 – a 30-hour longcase (note the absence of winding holes in the dial)

2.4 English dial clock

The English dial clock is very popular with collectors. They usually have a simple and robust movement, many of them using a “fusee”. A fusee evens out the torque from the mainspring as it unwinds, which helps improve timekeeping. We will look at the fusee in some detail later in the course.

Where the case descends below the dial, to accommodate a longer pendulum, it is known as a “drop dial” clock.



Figure 9 – English dial clock



Figure 10 – English drop dial

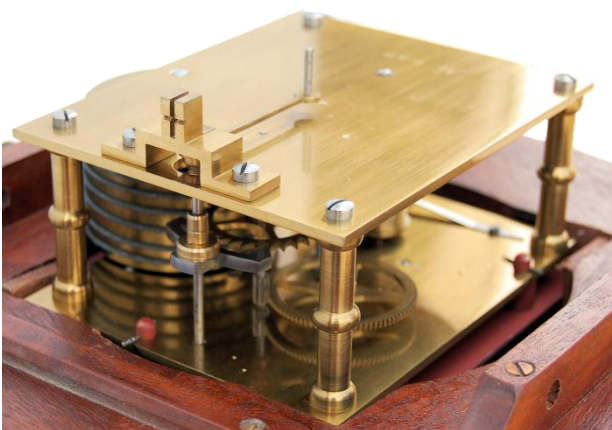

Figure 11 – drop dial movement (the fusee chain is visible, wrapped around the barrel)

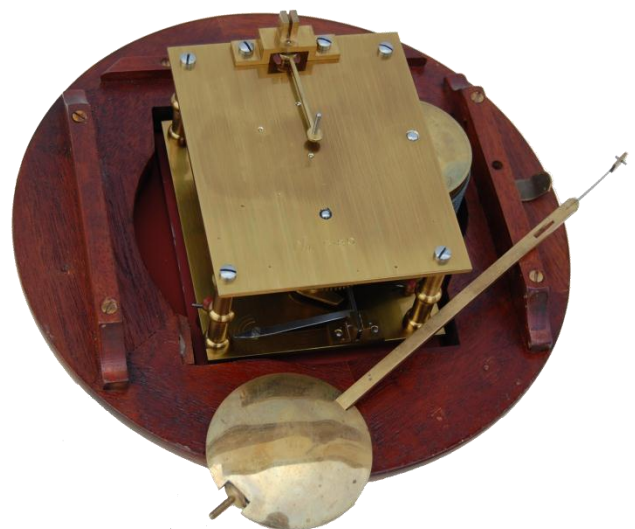

Figure 12 – drop dial movement showing typical pendulum

2.5 American wall clock

America mass-produced large numbers of clocks in the 19th and early 20th centuries. Thousands were imported into Britain, and they are still commonly found. The cases tend to be more ornate than the English dial clock.



Figure 13 – American wall clock by Ansonia

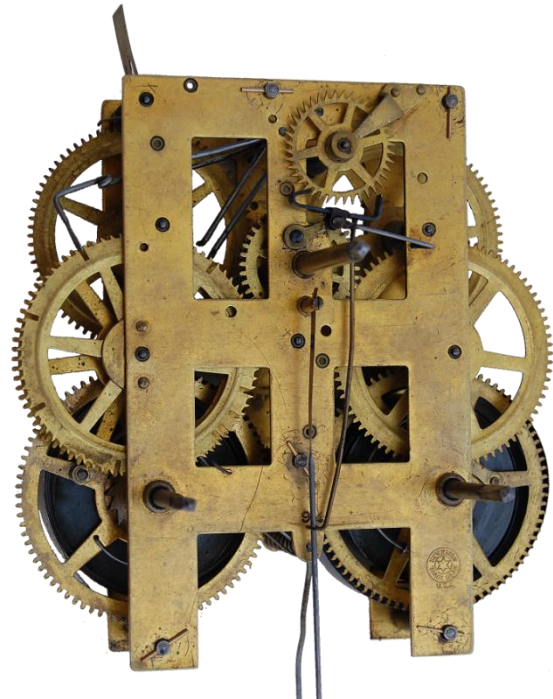

Figure 14 – Ansonia movement, front view

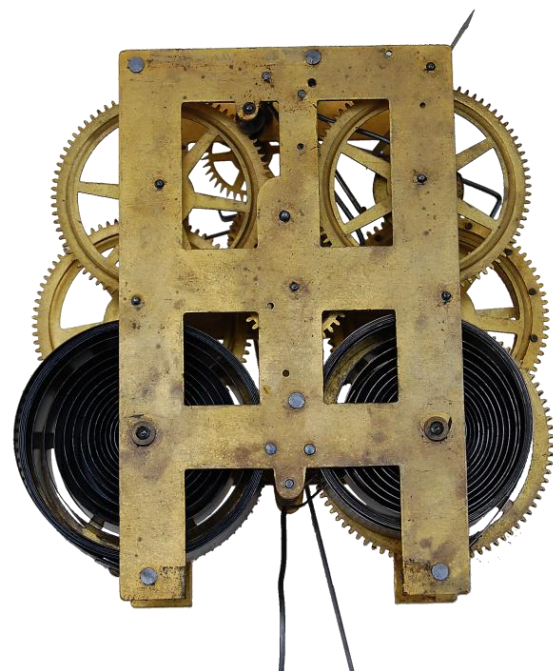

Figure 15 – Ansonia movement, rear view

2.6 Carriage clock

The carriage clock combines portability with compactness and an attractive appearance. It is no surprise that they are still popular to this day. Most of the ones you come across will be 19th century French. The movements are of good quality, with very hard steel parts which resist wear well. The platform escapement is visible through a window in the top. Some carriage clocks have a protective leather case.

The terms “balance” and “balance wheel” are used interchangeably in horology, and you will hear both in use. However, the former is regarded by experts as the more correct.

You will learn a lot more about the balance as the course progresses.

We will look in detail at the platform escapement later in the course, but for now note that the use of a balance means that the clock can be transported without having to stop it, so it will keep time on a journey. Pendulum clocks do not work when subjected to movement; moreover extreme movements of the pendulum may damage the clock. Consequently, pendulum clocks must be stopped and the pendulum safely stowed before they are moved.



Figure 16 – carriage clock



Figure 17 – carriage clock rear, showing attractive finish

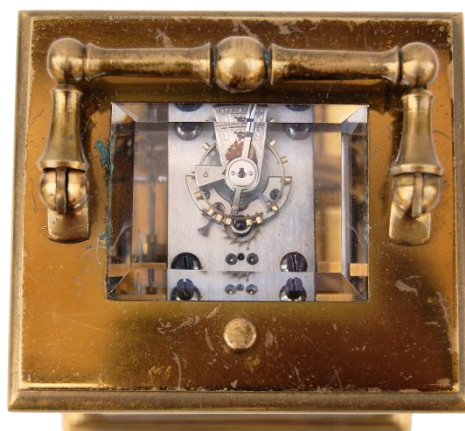

Figure 18 – visible platform escapement

2.7 French clock with a drum movement

French clocks with a drum movement were made in vast quantities, and in all sorts of styles. As with carriage clocks, most of the ones you come across will be 19th century. They are characterised by a round – drum-shaped – movement, usually protected by a metal sleeve, and fitted into a close-fitting round hole in the case. As a general rule the quality and finish of the movements is high. Drum movements were made with either a pendulum or a balance – both types are quite common. Usually the balance is on the back rather than on the top, as in this example.



Figure 19 – typical example of a French clock with a drum movement



Figure 20 – drum movement showing platform escapement



Figure 21 – another view, showing typical proportions of a drum movement

2.8 Vienna regulator

Vienna regulators are wall-mounted clocks. They were made between about 1790 and 1910 (although modern reproductions are still being made to this day, mostly with German-made Hermle movements). The first ones were made in Vienna, although manufacture spread throughout the German-speaking countries. Although there are numerous variations, they generally have an ornate wood case with glass in the sides and front. They are key wound and have visible weights which descend below the movement. They normally use a Graham dead-beat escapement (we will look at these later in the course) and a wooden pendulum rod with a large, disc-like bob in polished brass.

They use a shorter pendulum than a longcase clock, and have a pleasing appearance even to modern eyes.

The wood pendulum rod (which is relatively insensitive to temperature variations) combined with the dead-beat escapement allows the Vienna regulator to keep good time, although – despite their name – they should not be confused with the true

regulator clocks mentioned in section 2.3.

You should also note that some clocks in the Vienna Regulator style are spring-driven.



Figure 22 – typical Vienna regulator

2.9 20th century mantel clock

Clocks to be placed on mantelpieces were mass-produced in many countries throughout the early- and mid-20th century (and, with quartz movements, continue to this day). Case styles vary considerably, although the “Napoleon hat” style was popular and will be familiar to most people. The quality of the movements varies considerably. Single-train, two-train (time and strike) and three-train (time, chime and strike) variants were made. Some are easy to work on, others can be extremely tedious to set up, which means some clock repairers turn them away. It frequently costs more to service one than it is worth in monetary terms. However, many such clocks have a high sentimental value, which means customers will often pay the relatively high cost of servicing.

The clock shown in Figure 23 and Figure 24 is a fairly low-cost clock, although the Bakelite case makes it slightly unusual and more collectable. In the rear view you can clearly see the hammer and wire gong used for striking the hours, and behind it is the pendulum.



Figure 23 – 20th century striking mantel clock with Bakelite case

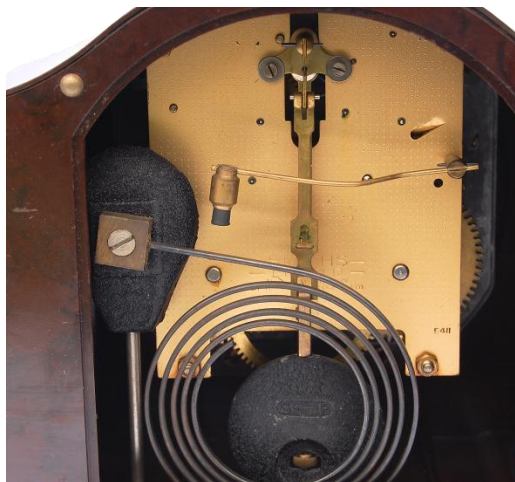

Figure 24 – rear view showing strike hammer and gong

The clock shown in Figure 25 and Figure 26 is a typical striking and chiming clock. It has a three-train movement and you can see the chime rods below the movement (which are also used for striking). There were many thousands of clocks of this type produced in varying qualities.



Figure 25 – 20th century chiming mantel clock

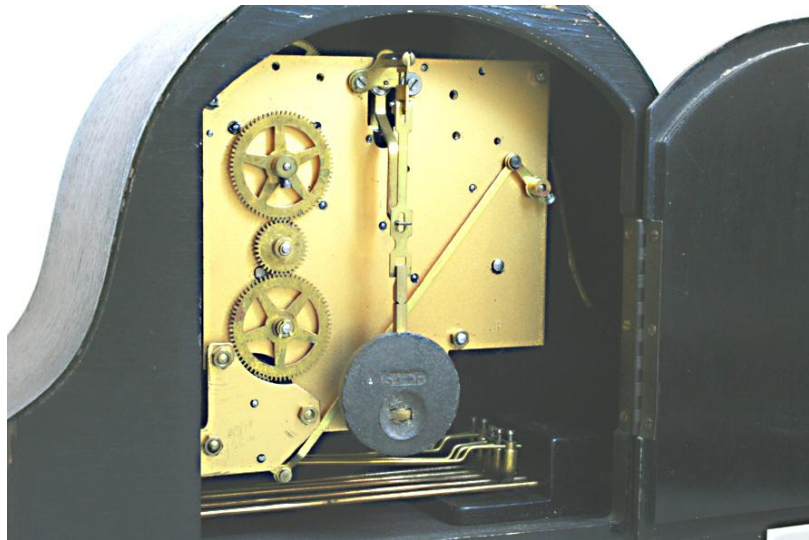

Figure 26 – rear view of chiming mantel clock showing gongs and hammers

We should also mention the “floating balance” clock. This one was made by Smiths in the 1950s. You can see that the balance is horizontal and suspended on a helical spring. The balance runs on a fine wire down its centre, but literally floats vertically. This clever arrangement results in a very low level of friction on the balance, and allowed Smiths to make an 8-day clock more cheaply – and in a more compact form – than the pendulum clocks you have seen above. Also, pendulum clocks can be damaged when moved around unless the pendulum is removed or constrained – something many owners do not understand. The floating balance clock is fully portable without harm.



Figure 27 – 1950s Smiths mantel clock

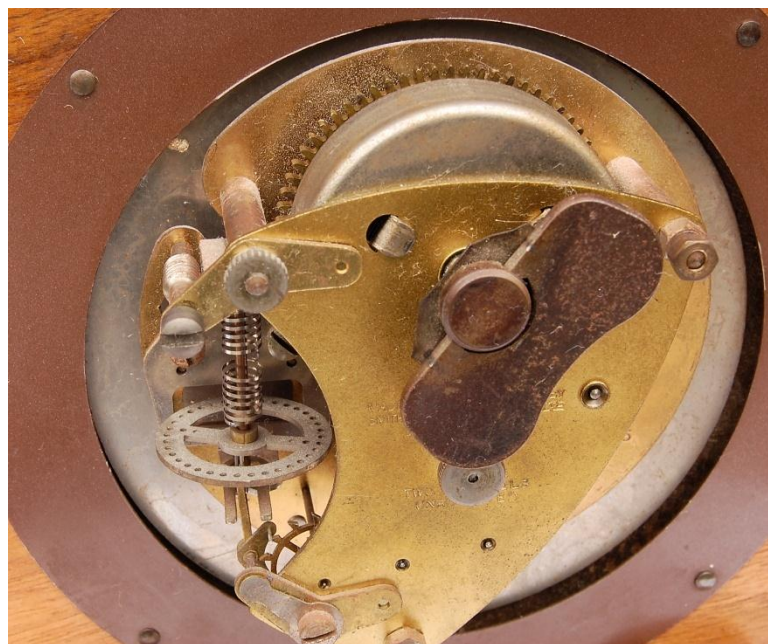

Figure 28 – floating balance

2.10 Appearances can be deceptive

Here is a fairly unassuming 20th century clock, made in the traditional style of a bracket clock. However, when you look in the back you see a superb quality movement with a platform escapement. At this stage in your horological learning, if you come across a clock like this that needs servicing you would be well advised to take it to an experienced and qualified professional – a Member or Fellow of the British Horological Institute.



Figure 29 – 20th century chiming clock in traditional style



Figure 30 – rear view of a high quality chiming clock

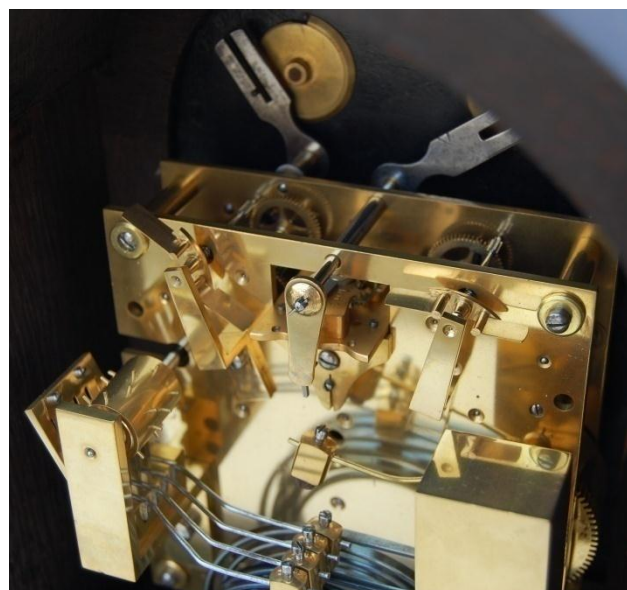

Figure 31 – another view (note the platform escapement mounted between the plates)

2.11 400 day (anniversary) clock



Anniversary clocks were made throughout most of the 20th century, the majority being made in Germany. By using a special “torsion” pendulum which rotates back and forth extremely slowly, it is possible to make a clock which runs a whole year on one winding. This made anniversary clocks popular for commemorative gifts. Also, the slowly rotating pendulum has a distinct visual appeal which makes them desirable to some people.

Their timekeeping is usually quite poor, and some clock repairers find them difficult to set up. However, provided the correct techniques are used, they pose no real problems.

Figure 32 – 400 day (anniversary) clock

2.12 20th century alarm clock



The Smith Alarm is probably the archetypal 20th century alarm clock. Mass produced in vast numbers, they found their way into virtually every British home. Despite their popularity they were rather unreliable and not very durable. The Westclox Big Ben (not shown) was a more recent competitor and proved more reliable, as well as having a quieter tick (important in a bedroom).

Figure 33 – 20th century Smith alarm clock

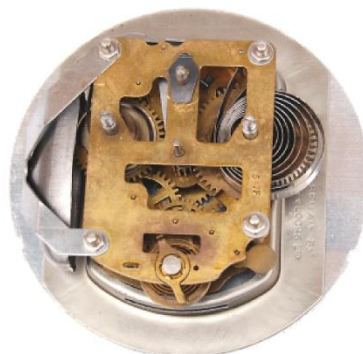

Figure 34 – movement of Smith alarm clock



Figure 35 – late 20th century Japanese alarm clock

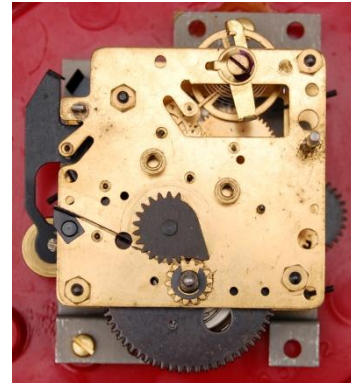

Figure 36 – movement of Japanese alarm clock

In the 1970s the Japanese made inroads into the alarm clock market using the Rhythm brand, amongst others. At first glance the movement seems similar in technology to the Smith Alarm, but in fact they were far more reliable and durable due to improved manufacturing techniques and needed little or no servicing for years at a time.



Figure 37 – late 20th century Chinese alarm clock



Figure 38 – late 20th century Chinese alarm clock, showing plastic movement parts

In the late 20th century the Chinese had entered the market. By now quartz alarm clocks were in widespread use, but mechanical clocks still had an attraction if they were distinctive enough. This one uses plastics for almost every part, to remarkable visual effect.

2.13 Quartz clock



Figure 39 – standard quartz clock movement



Figure 40 – standard quartz centre nut

Everyone is familiar with the quartz clock and they are to be found everywhere. The movements are small (approximately 52 mm wide x 45 mm high), cheap, accurate, reliable and durable. Virtually all quartz movements are fixed with a slotted nut which screws onto the movement from the front of the dial – Figure 40. Sometimes it is hidden, but if you see something like this in the middle of the dial you can be pretty sure there is a quartz movement behind it.

The low cost and compact size of the quartz movement makes it very popular for novelty clocks, such as the one shown here.



Figure 41 – quartz novelty clock

2.14 Radio-controlled clock



Figure 42 – radio controlled quartz movement

Radio-controlled clocks are based on quartz clock technology, but they also have a radio receiver which receives the time signals broadcast in most countries. An electronic circuit corrects the quartz clock to the broadcast time, usually twice a day. This means that the clock never needs to be put right; it will even correct itself automatically after a battery change.

They cannot normally be serviced, but replacement movements are easily obtained. They generally use the same method of fitting as a standard quartz movement.

2.15 English lever pocket watch



Figure 43 – English lever watches, front and rear views

Here are two typical English lever pocket watches (“lever” referring to the type of escapement – we will look at them later in the course). They were made using special machinery, but not mass-produced in the modern sense. You will see that the dials, and the movements, have different signatures, but in fact the movements are clearly identical. This is very normal with English lever watches – they were made in various degrees of completeness, and then “finished” prior to sale. Note that despite the obvious similarity of the movements, the parts may not be interchangeable between them. This is due to relatively poor control of manufacturing tolerances – many parts being hand finished to fit.

2.16 American railroad pocket watch



In the late 19th century many of America's railroads were still single track. This required sophisticated time management of the trains so they were not at risk of collision. It was not always successful – in Ohio in 1891 an engineer's watch stopped for four minutes and then restarted. The end result was a serious crash with fatalities and property damage. In response, the railroad industry designed a specification for the watches its staff must use. The specification covered the construction as well as the performance requirements (for instance, they must keep time to within four seconds a day in any of five positions, as well as over a wide temperature range). The time may only be set by removing the bezel and pulling

out the setting lever (see the top left photo), which made it impossible to accidentally disturb the time setting when winding the watch.

The American watch industry met the challenge with enthusiasm and success. Unlike the watch industry in Britain at that time, the Americans used modern mass-production techniques. Shown above are two Hamilton railroad watches. The one on the left is relatively early – 1904, and the one on the right was made in the 1930s. Many people believe that the American railroad watch is the pinnacle of mass-produced mechanical watches. Even modern day Swiss mechanical watches are remarkably similar in design and construction – and performance – to the railroad watches.

You will also see that the manufacturers applied a superb finish to parts of the movement, including machined damaskeening (normally spelt “damascening in Europe, with a silent ‘c’”) and beautiful engraving embedded with gold leaf. They wanted to signal to potential purchasers the high quality of their product. As the 20th century progressed the watches continued to improve in quality and performance, but there was much less emphasis on the relatively high-cost decorative finishes, so more recent ones are sometimes regarded as less desirable, despite their superb quality and performance.

2.17 Mechanical wristwatch

As soon as your friends find out you are studying horology you are certain to be asked to repair countless old watches dragged out from the backs of drawers.



Figure 45 – late 20th century Japanese (left) and Russian wristwatches

The number and variety of 20th century mechanical watches is vast. Two watches are pictured in Figure 45; they illustrate the different tastes of two cultures: the one on the left is made in Japan for the European market; the one on the right is made in Russia for the home market.



Figure 46 – examples of the more "characterful" watches you may come across

You will also come across some superbly characterful watches. The one on the left in Figure 46 was bought in China – Chairman Mao waves his arm when the watch runs. On the right is a magnificent example of a watch that has clearly earned its keep. Every surface is deeply scored; it has been knocked so many times the outline of the movement has imprinted itself on the dial; and the back of the watch has been corroded right through by sweat. It has obviously faithfully served its owner – perhaps a labourer or workman – for many years, if not decades, and it is still in perfect working order. Its history is deeply etched into the watch, and this may have great appeal to the owner. On the other hand, even a watch in this state can be restored to pristine condition.



Figure 47 – 20th century ETA and Bulova movements

On the left in Figure 47 is an example of the popular ETA 2824-2 movement. It is a fast train movement (these terms will be explained later in the course) of good

quality and is found in numerous mid-range Swiss watches. The semi-circular rotor covering half the movement is the automatic winding weight.

To the right is a beautiful movement by Bulova. This uses a so-called micro-rotor for the automatic winding – visible at the 9 o'clock position – which sits *within* the movement, rather than on top of it. This makes the movement slimmer and allows the use of a more elegant, low-profile case.

2.18 Quartz analogue wristwatch

Perhaps surprisingly, quartz analogue watches are eminently repairable. Again, though, the only reason to do so would be when the watch has some sentimental value. In most cases it is cheaper to buy a new watch.



Figure 48 – two quartz analogue watches

Good quality quartz analogue movements can be dismantled and serviced much like a mechanical watch. Some low cost quartz movements cannot, but they can usually be replaced in their entirety for a very reasonable cost – again making repairs viable.

The Tissot shown in Figure 48 is one of the earliest quartz analogue watches, made to a very high standard, before market pressures forced cost reductions. The Citizen to the right is interesting in that it is powered solely by heat from the wearer's body.

2.19 Quartz digital watch



Figure 49 – Quartz LED digital watch

Most quartz digital watches use either a light emitting diode (LED) display, or a liquid crystal display (LCD). LED displays were used on early quartz digital watches from the 1970s, but they had two major disadvantages. Firstly, they use a lot of electrical current, so the watch battery would often last just a few months. Secondly, in order not to discharge the battery in mere minutes, the display was switched off until a button was pressed. Thus, both hands were required to tell the time. Figure 49 shows a typical example of such a watch. The time display button is visible at the upper right of the case. The dark red – almost black – appearance of the dial is typical of these watches.

LCD watches replaced them. An LCD display uses an extremely small amount of power, so the time can be permanently displayed. However, unlike an LED watch which lights up in the dark, or an analogue watch which can have luminous hands, an LCD watch requires a backlight for night time viewing. Even so, this is a relatively small disadvantage. The watch in Figure 50 is extremely rare, but is shown to illustrate the first type of liquid crystal display used in watches. Watches like that in Figure 51 have been made from the late 1970s onwards.

Quartz digital watches are not serviceable in the normal sense, but the movements can be replaced. However, replacements are not as easy to find as quartz analogue movements.



Figure 50 – very early LCD watch with "random dispersal" display



Figure 51 – a good quality LCD watch (this cost the owner a week's wages in 1977)

3 Is time smooth?

The true nature of time is still being debated by physicists and philosophers, and such discussions are sadly beyond the scope of this course. However, most people would agree that time seems to move smoothly and continuously. Therefore it is natural that the first timekeepers also used a smooth, continuous process to represent the passage of time.

Candles with regular marks along their length are an obvious example. Water clocks (clepsydras) of varying levels of sophistication were developed, although all of them relied on the steady flow of water through a small hole or constriction.

In the collection of the British Horological Institute is an incense clock (Figure 52). Several pairs of weights are suspended over a tray, each pair being held by a piece of string. The strings are evenly spaced apart and stretched horizontally across a frame. A burning stick of incense is placed across the strings. The incense burns along its length at a constant rate, and each time the smouldering end reaches a string, the string burns through allowing the weights to drop onto the tray. The audible clangs of the falling weights indicate the passage of time.

The hourglass is another example of a smooth, continuous process being used to measure the passage of time. The sand trickling through a small constriction means they operate in much the same way as a clepsydra. Interestingly, though, the earliest solid evidence for the hourglass goes back only to the 14th Century.

You can see that people have been quite inventive in this field, and we might expect timekeepers using a smooth, continuous motion would measure the smooth passage of time with great accuracy.

Even though this seems like common sense, by a strange quirk of physics it turns out not to be the case. In fact the most accurate timekeepers use a totally different principle; they rely on something moving regularly between two states: an oscillator.

There are many types of oscillator, but all modern timekeepers (apart from a sand-filled egg timer) rely on an oscillator of some sort.



Figure 52 – incense clock

important concepts

The standard way of measuring frequency is in cycles per second. The unit of frequency is the **Hertz**, abbreviated to Hz and pronounced "hurts". One cycle per second is 1Hz. For historical reasons we usually use **beats per hour (bph)** in horology. There are normally two beats (or ticks) to each oscillation, so that a timekeeper ticking six times per second oscillates at 3Hz, and beats at:
 $6 \times 60 \times 60 = 21,600\text{bph}$.

A 2Hz oscillator completes two cycles in a second – the time for one cycle is thus half a second. It is simple to convert between frequency and the time for one cycle:

frequency (in Hz) =
 $1 / \text{time for one cycle (in seconds)}$

time for one cycle (in seconds) =
 $1 / \text{frequency (in Hz)}$

4 The oscillator as a timekeeper

Anything that goes back and forth between two positions with reasonable regularity is said to oscillate. Oscillations are found everywhere, from the swaying of a tree branch to the vibrations of a violin string. The complete motion from one extreme position to the other and back again is called an oscillation, or a cycle. The number of cycles in a given period is called the frequency. *For more information read the box to the left.*

For timekeeping purposes, mechanical oscillators are more stable, and easier to implement, than the continuous motion devices mentioned previously. An example of an early mechanical oscillator is the verge and foliot, used throughout Europe in the 15th and 16th Centuries. The verge and foliot is described in Lesson 12.

In the year 1581 Galileo discovered the properties of the pendulum, which is the first known **resonant oscillator**. Resonant oscillators have a natural frequency of vibration, in contrast to the verge and foliot, for example, which has no natural frequency and is thus non-resonant.

The discovery of the resonant oscillator was the greatest breakthrough in the history of horology, and gave the potential for massive improvements in timekeeping accuracy. There are two common forms of the resonant mechanical oscillator: a weight acting against gravity (i.e. a **pendulum** – Figure 53); and a weight acting against a spring (i.e. a **balance** – Figure 54). All modern mechanical timekeepers use one of these forms. We will look in detail at both of these during the course.



Figure 53 – a mantel clock pendulum

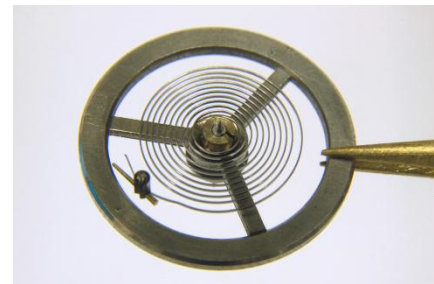

Figure 54 – a balance

For reasons outside the scope of this course, it turns out that – all things being equal – high frequency oscillators keep better time than low frequency ones. Harrison realised this when he abandoned his third attempt at a marine chronometer and used a watch for his fourth, successful, attempt. There are limits to how rapidly a mechanical device can oscillate,

but the world of electronics is not constrained in the same way. The balances in modern mechanical watches typically run in the range 2.5 to 4 cycles per second, but the quartz crystal in a modern watch typically oscillates at over 32,000 cycles per second. That is one reason why they keep much better time than a mechanical watch. The most accurate timekeepers of all, atomic clocks, oscillate several billion times per second.

5 Basic divisions of a mechanical movement

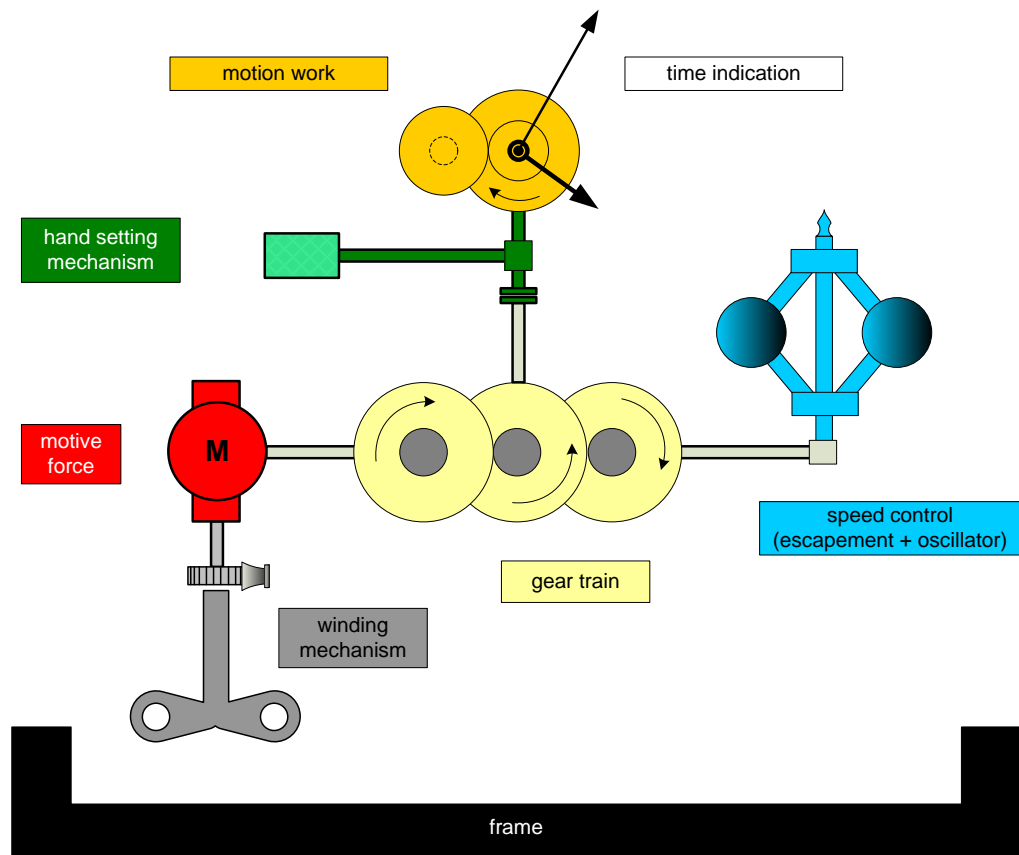

Figure 55 – the divisions of a mechanical movement

All mechanical watches and clocks work on the principle shown here.

- a **motive force** drives a **gear train**
- the gear train operates some form of **time indication** (which usually employs **motion work**)
- a **speed controller** controls the speed of the gear train, such that the time indicator accurately shows the passage of time (the speed controller consists of an **escapement** and an **oscillator**)

In addition we have:

- the **frame**, which acts as the chassis for the rest of the mechanism; for clocks, it is usually two plates held apart by pillars. There are separate bridges and cocks where necessary. A modern watch consists of one plate with bridges and cocks.
- a **winding mechanism**, which allows us to replenish the energy in the weight or the spring
- a mechanism for **hand setting**, so we can set the clock or watch to the right time

In horology, the term “gear train” is usually abbreviated to “train”, and this is regarded as the preferred usage.

You will hear both terms used.

You can see straight away that the speed controller is crucial in making the clock or watch indicate time accurately. A good speed controller will ensure the train runs at exactly the same speed even if the motive force varies, or if the train suffers from varying friction. We will come back to this in much more detail later.

5.1 The motive force

We do not want a timekeeper which requires a continuous supply of external energy, as this would be very inconvenient. Therefore we need a device which stores energy, such that we can replenish it at convenient intervals. There are two energy storage systems used in mechanical timekeepers: weights and springs.

A weight stores energy when it is lifted from the ground, and releases the energy as it descends. By lifting the weight at regular intervals, we provide it with enough energy to operate the clock for the intervening period.

A spring stores energy when it is tightly wound, and releases it as it unwinds. We store energy in the spring by “winding it up”.

In both cases the stored energy acts on the train as **torque** (turning force). The spring or weight is coupled to the first wheel in the train, which is commonly called the “great wheel”. As the torque is allowed to turn the train, the stored energy is gradually dissipated.

For a clock, the torque from a descending weight is always constant until the weight can descend no longer. This makes the design of the rest of the clock simpler and gives the potential for very stable timekeeping. On the other hand, a weight-driven clock requires room for the weights to fall, which is a disadvantage. Also, weight-driven clocks cannot be carried around. A spring drive shows a diminishing torque as the energy is dissipated, but timekeepers using a spring can be made compact and portable. The ultimate example of this is, of course, the wristwatch.

In theory, the stored energy from either system could appear as a very small torque at the first wheel, but which can be maintained over a large number of turns; or a large torque which can be maintained over just a few turns.

It happens that both weights and coil springs work best in the latter arrangement; that is, generating a lot of torque but only over a few turns.

5.2 The winding mechanism

Most mechanical clocks are wound by turning an arbor which lifts the weight, or winds the spring; a watch is wound by turning the winding crown. The arbor is prevented from turning backwards (thus unwinding the clock or watch) by a simple **ratchet** mechanism comprising a ratchet wheel, click and click spring.

5.3 The train

It also happens that all the commonly used speed controllers require a very small torque (compared with the motive force) over lots of turns, so we use a train to reduce the torque from the first wheel and increase the available turns. Each stage in the train divides the torque and multiplies the number of turns. In other words, the train converts *high-torque, few-turns* into *low-torque, many-turns*.

The train also provides a suitable place to derive the time indication. We will discuss this shortly.

5.4 The speed controller (escapement and oscillator)

You will recall our discussion in section 3 above about time flowing smoothly. We pointed out that maintaining a smooth, continuous motion at a constant rate is very difficult to do accurately, whereas we can make devices which move back and forth – oscillators – with great accuracy. Therefore we want an **oscillator** at the heart of our speed controller.

There is no easy way of converting the smooth, continuous motion we want in our train into a back and forth motion for our oscillator. Luckily, it does not matter – we can compromise. We can allow our train to move in steps, provided they occur closely enough together. For instance, the time indication on a quartz analogue watch with a seconds hand moves in one second steps, which is perfectly acceptable for normal purposes.

Allowing the train to move in small steps turns out to be essential to overcoming the problem of using an oscillator as the time reference.

A device called the **escapement** sits between the train and the oscillator. It has two jobs: firstly, it provides energy to the oscillator to keep it going; secondly, it releases the train in small steps, *under the control of the oscillator*, so the train runs at the required speed. The escapement plays a key role in all mechanical clocks and watches. There are numerous designs of escapement, and in due course we will be studying several of them closely.

5.5 The time indication

We now have our train running at the desired speed. The timing indication is traditionally one or more hands moving around a dial, although timekeepers with a digital readout have been made.

5.6 The motion work

Most clocks and watches have the minute and hour hands mounted concentrically. The minute hand turns twelve times for one turn of the hour hand. The gearwheels which do the job of driving the concentric clock hands at the appropriate 12:1 ratio are called the **motion work**. The motion work is driven from a convenient point on the train.

5.7 The time setting mechanism

The hands must be settable to the correct time even though the escapement and oscillator limits the speed of the train. This is achieved by a friction drive between the train and the motion work. As the movement runs, the friction drive turns the hands but the user can overcome the friction in order to adjust the hands to the correct time. Some clocks are set simply by moving the minute hand round; others have a knurled knob geared to the motion work. For the watch, the winding crown is pulled outwards so that, when turned, the position of the hands is adjusted.

5.8 The frame

On most clocks the frame consists of a front plate and a back plate, with three to five pillars between them. Bridges and cocks are used to provide support for arbors extending beyond the plates. Figure 56 shows some plates from a French drum

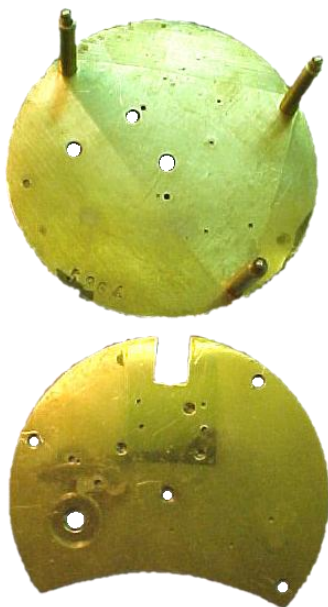

Figure 56 – example clock plates with pillars

clock. Early watches were made using a similar construction but modern watches use a main plate with bridges and cocks – Figure 57.

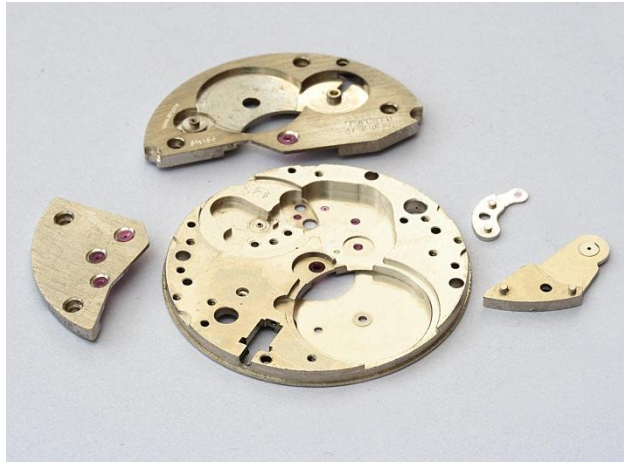

Figure 57 – example watch plate, bridges and cocks

5.9 Summary

The basic divisions of a mechanical movement are:

- frame
- motive force
- winding mechanism
- train
- time indication, including motion work
- hand setting mechanism
- escapement
- oscillator

6 A hands-on look at a simple clock

If you are thinking about dismantling a clock to look at the component parts, it is essential that the mainspring is let down before you start. Look in the Clock Servicing section of Lesson 4.

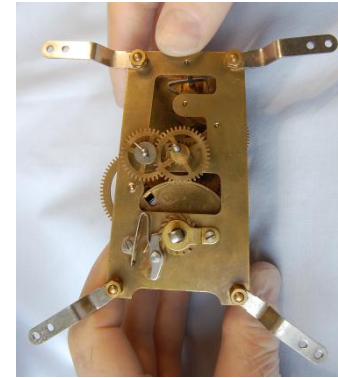

Figure 58 – front view of movement

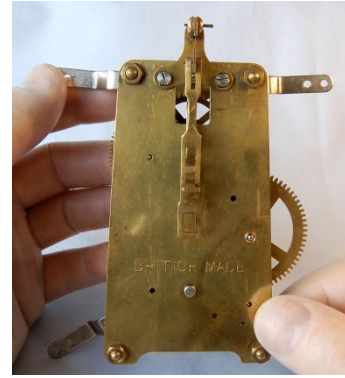

Figure 59 – rear view of movement

6.1 Overview

Our clock is a mid-20th century Bentima mantel clock movement, shown in Figure 58 and Figure 59. In these two photos you can see the brackets for mounting the movement to the clock frame. We have removed these for all the subsequent photographs.

6.2 Motion work



Figure 60 – motion work on the front of the clock

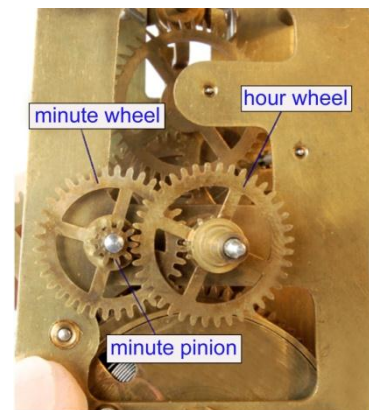

Figure 61 – minute wheel and hour wheel

The **motion work** allows the minute and hour hands to be mounted concentrically, and provides the required 12:1 ratio between them (i.e. twelve turns of the minute hand results in one turn of the hour hand). Lesson 2 explains this much more fully.

In Figure 61, we have removed the tapered pin and washer which retain the **minute wheel**. You can now see that the **minute wheel pinion** (the smaller gear, sometimes called the **minute pinion**) engages with the **hour wheel**. The hour wheel is so called because it carries the hour hand. The name of the minute wheel could be confusing because it does not carry the minute hand, nor does it turn once a minute. It merely acts as the intermediary between the cannon pinion and the hour wheel.

In Figure 62, the hour wheel is lifted clear, revealing the cannon pinion, which is pressed onto the **centre arbor** (an arbor is the horological term for an axle or shaft).

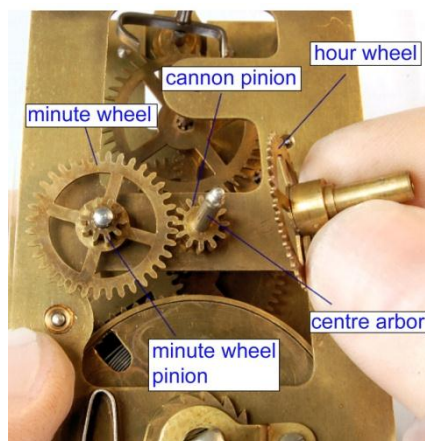

Figure 62 – the hour wheel lifted clear

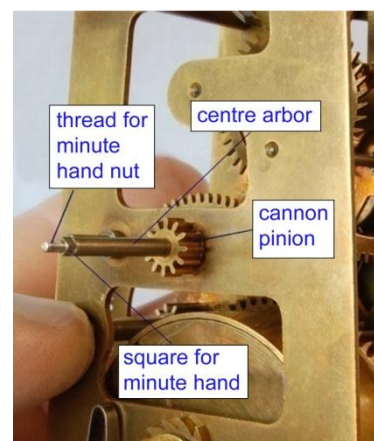

Figure 63 – centre arbor and cannon pinion

It should now be clear that the drive from the centre arbor (which carries the minute hand) goes via the cannon pinion to the minute wheel; the pinion attached to minute wheel then drives the hour wheel.

The centre arbor is more easily visible in Figure 63, where you can see the square upon which the minute hand sits, and the threaded portion for the nut which retains the minute hand.

6.3 Pendulum and crutch

Mounted at the top of the **back plate** is the **back cock**. The upper part of the **suspension spring** is held in the slot in the back cock by a taper pin. The top part of the **pendulum rod** hooks onto another pin through the lower part of the suspension spring. In Figure 65, you can also see the **crutch**, which engages with a vertical slot in the upper pendulum rod. The crutch moves from side to side with the pendulum, and transmits the small force necessary to keep it swinging.

A close-up of the suspension spring is shown in Figure 66. The suspension spring carries the weight of the **pendulum** and allows it to swing from side to side. In this instance the suspension spring is two narrow springs side by side.

Figure 64 shows the complete pendulum, consisting of the upper and lower rod, with the **bob** at the bottom. The bob can be raised or lowered using the knurled **rating nut** in the middle, which engages with a threaded portion of the lower pendulum rod.

*Raising and lowering the bob alters the **rate** of the clock, so we can adjust it to keep good time.*



Figure 64 – complete pendulum

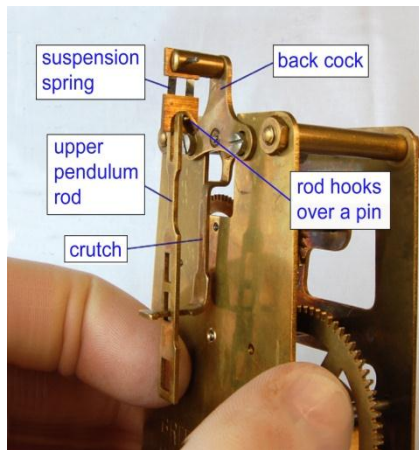

Figure 65 – mounting the pendulum

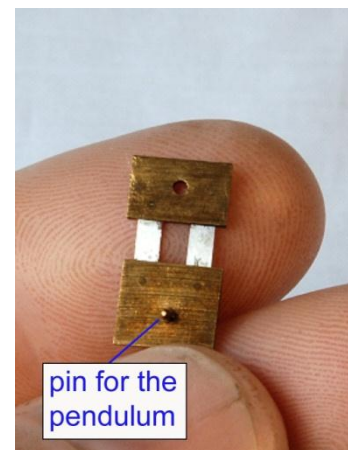

Figure 66 – suspension spring

This pendulum bob is made from cast metal, but often it is a brass case filled with lead.

Some clocks have a different type of crutch and pendulum rod. More details are given in Lesson 3.

6.4 Cocks and bridges

Bridges and cocks are part of the frame of the clock; they are fitted where an arbor extends beyond the plate and requires a pivot outside the plate. A bridge has two or more fastenings to the plate whereas a cock has just one.

We will look in more detail at cocks and bridges in Section 6.12.

There is one case where this naming rule is broken: the “back cock”, which we discuss next.

6.5 Back cock and pallets



Figure 68 – back cock in situ



Figure 67 – close-up of back cock

Figure 68 and Figure 67 show the **back cock**, which is clearly a bridge because it has two screws to fasten it to the clock plate. Even so, it is always called the back cock. The slot for the upper part of the suspension spring is clearly visible.

In this instance the screw holes are slotted to allow the position of the back cock to be adjusted to alter the depth of the pallets with the escape wheel. In some clocks there is no adjustment; the back cock is located precisely with steady pins. Another approach, often found on French drum movements, is a “turntable” – a separate circular piece of brass lightly riveted in the front plate. The pivot hole is off centre so that turning the “turntable” will adjust the position of the pivot hole and therefore the depth of the pallets. The brass turntable usually has a slot for adjusting with a screwdriver. It is very tight and usually no alteration to the depth is required.

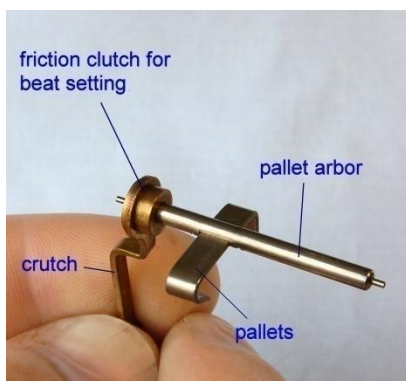

Figure 69 – pallet assembly



Figure 70 – close-up of pallets

The **pallet assembly** – Figure 69 – has been taken out of the clock.

Pallets are made in two ways: bent strip pallets, as found in this clock, or using a steel forging or steel plate. Bent strip pallets are cheaper in production and found in less expensive mass produced clocks. The acting faces, the pads, are hardened and highly polished.

The **pallets** are mounted on the **pallet arbor**. In this instance the pallet arbor has a friction device connecting it to the crutch. This lets us adjust the relative position of

the crutch and the pallets, which is used to set the clock in beat (to give it an evenly spaced tick-tock-tick-tock). The pallet assembly is part of the escapement, which we will look at in more detail in Lesson 3. As the pendulum swings from side to side, the pallet assembly, being linked to the pendulum by the crutch, rotates about the axis of the pallet arbor. This movement of the pallets allows an escape wheel tooth to be released, which, at the same time, impulses the pendulum to keep it swinging.

6.6 Winding mechanism

Deficiencies in any part of the winding mechanism can cause serious hazards to the person winding the clock, and the clock itself. We will discuss this in more detail in Lesson 2.

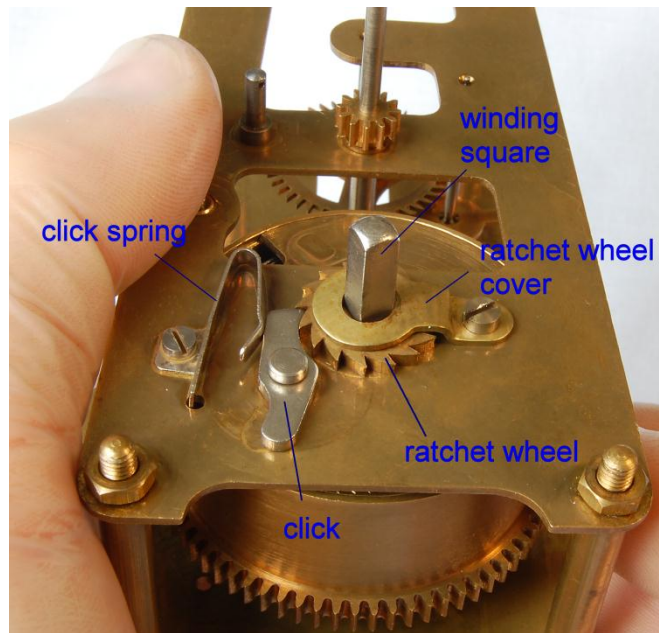

Figure 71 – the winding mechanism

Figure 71 shows the complete **winding mechanism**. The **winding square** is formed on the end of the **barrel arbor** (section 6.9). The key (not shown) fits the winding square and is used to turn the barrel arbor, winding the spring inside the barrel.

The ratchet wheel fits over the winding square and turns with the barrel arbor.



Figure 72 – ratchet wheel cover



Figure 73 – ratchet wheel

The **click** is held on the front plate by a shoulder rivet, and is therefore free to rotate; it is held in engagement with the **teeth** of the **ratchet wheel** by the **click spring**. As winding takes place, the click snaps in and out of the ratchet wheel teeth, giving the characteristic “clicking” sound. When the key is released the click engages the ratchet wheel, preventing it from turning anticlockwise again when the key is released.

The **ratchet wheel cover** holds the ratchet in place, and is shown in Figure 72. Figure 73 shows the ratchet. The square hole fits the winding square on the barrel arbor so the two rotate together.

Figure 74 gives a close-up view of the click spring, and in Figure 75 you can see the foot which fits in a hole in the clock plate and keeps the spring properly located.

On some clocks the click is secured by a shoulder screw instead of a rivet.



Figure 74 – click spring in situ

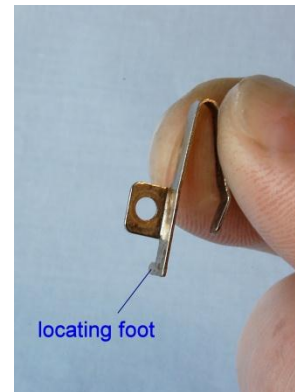

Figure 75 – detail of click spring

6.7 Overview of the train

Figure 76 and Figure 77 show two views of the **train**, and how it fits between the front and back plates. We will now look at the individual wheels and pinions.

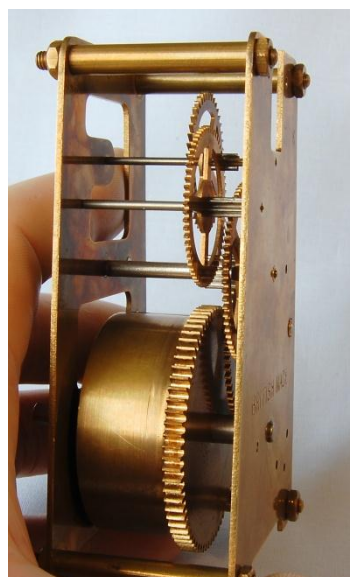

Figure 76 – the train in position

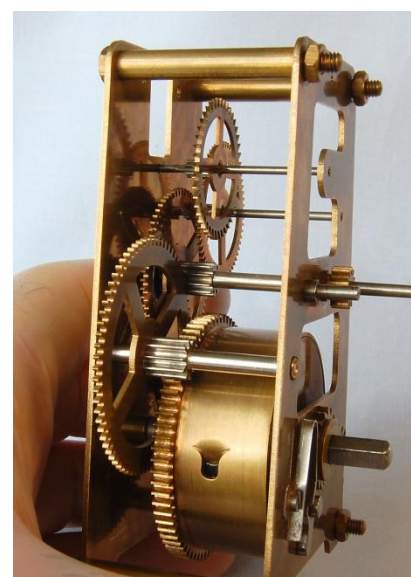

Figure 77 – another view of the train

6.8 A typical clock wheel and pinion

The train is made up of wheels and pinions on arbors. There are specific terms for each part which you need to know, as shown in Figure 78.

The wheels on our Bentima are mounted in a different way. Instead of using the traditional collet – Figure 78 – they are fastened directly to the pinion. A portion of the pinion has been turned down to locate the wheel, which is then riveted to it.

This method is more commonly found in low cost, mass-produced clocks.

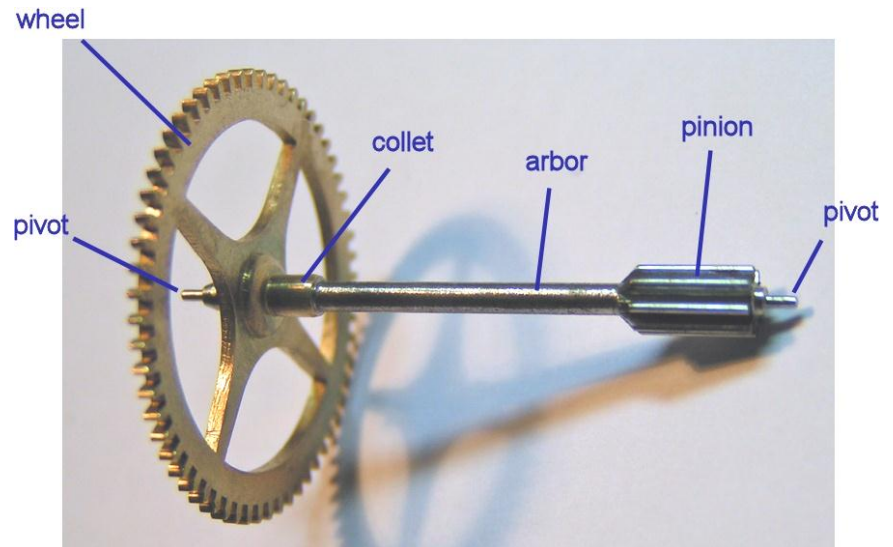

Figure 78 – a wheel on its arbor

This is a typical example of a wheel and pinion. The wheel has teeth all round it. The wheel is normally made from brass, and is riveted to the brass collet, which in turn is soft-soldered to the steel arbor. At each end of the arbor is a pivot, machined from the arbor. Each pivot runs in a hole in the front or back plate of the movement. The pinion is like a small gear wheel, but it also is machined from the same piece of stock as the arbor. The teeth on a pinion are properly called leaves.

In horology, a wheel generally has twenty or more teeth. An exception is the escape wheel, which may have fewer. Pinions have less than twenty leaves.

The pinion is polished and then hardened and tempered to reduce wear. The pivots are burnished to a shiny finish. Burnishing smooths the metal by “flowing” it, rather than abrading it. This work hardens the surface and makes the pivot less prone to wear.

The shoulders of the pivots (Figure 79) are slightly chamfered to eliminate sharp edges and reduce the diameter of the metal actually rubbing against the plate. This reduces the running friction of the train. The diameter of the pivot is typically about one third of the diameter of the arbor.

The wheel is **crossed out** to give four “spokes” of a traditional shape. Some wheels have more crossings. This reduces the mass of the wheel, improves its appearance, and saves on brass (which was, at one time, a scarce and expensive material).

When assembled into a train, the wheel on one arbor engages with the pinion on the next, thus providing a “gearing up” or multiplying effect. One turn of the wheel forces the driven pinion to make many turns. We will look at how to calculate the multiplying effect later in the course.

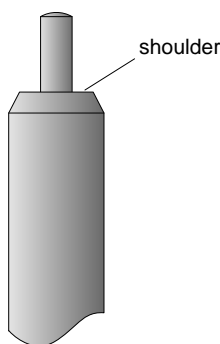

Figure 79 – the form of a typical pivot

Figure 80 shows the train in position, but with the back plate removed. In Figure 81, the direction of power flow through the train is shown by the thick black arrows, and the thin blue arrows show which way the wheels rotate.

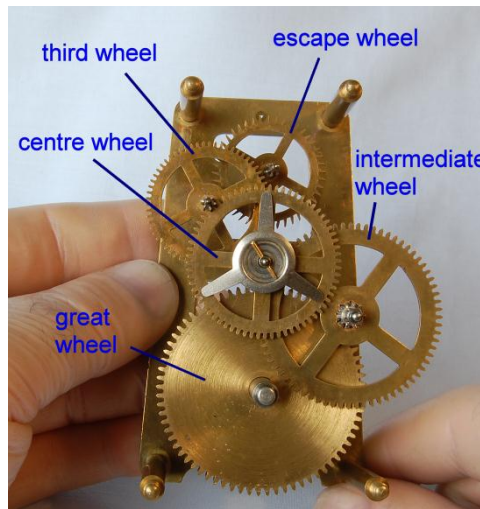

Figure 80 – the train wheels named

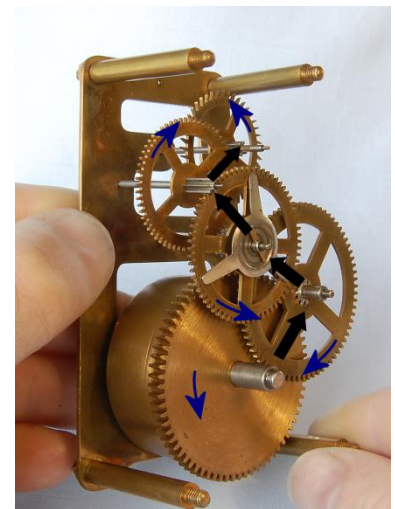

Figure 81 – power transmission through the train

6.9 Barrel and great wheel



Figure 82 – the barrel



Figure 83 – another view of the barrel

*This type of barrel is called a **going barrel**.*

The **barrel** contains the **mainspring**, which stores the energy to run the clock. The spring is hooked to the **barrel wall** and – when wound – tries to turn the barrel. The inner end is hooked to the arbor. Integral with the barrel is the **great wheel**. This is the first wheel in the train. In Figure 84, the **end cap** has been removed so you can see the spring inside. Turning the barrel arbor clockwise winds the spring, and as the barrel slowly rotates clockwise the spring unwinds again.



Figure 84 – barrel with end cap removed

6.10 Intermediate, third and escape wheels and pinions



Figure 85 – intermediate wheel and pinion

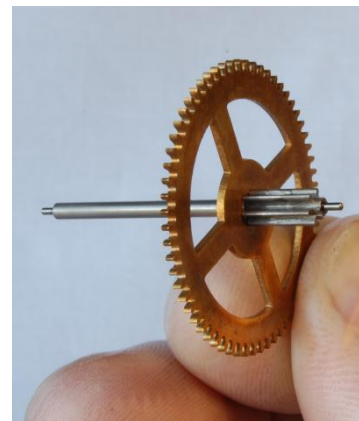

Figure 86 – third wheel and pinion

The **intermediate wheel and pinion** – Figure 85 – goes between the great wheel and the **centre wheel and pinion**. It is only used on clocks designed to run for a week or longer. In 30 hour clocks, the great wheel drives the centre pinion directly.

Note the sturdy pivots on the arbor of intermediate wheel – it must withstand a large amount of torque.

Figure 86 shows the **third wheel and pinion**. It is actually the fourth wheel in this train (after the great wheel, intermediate wheel and centre wheel). In a 30-hour clock there is no intermediate wheel, so it would be the third wheel. The nomenclature is retained whether it is a 30-hour or 8-day clock: the third wheel is always the wheel after the centre wheel. You can see that the pivots are finer as it operates under much less torque.

We talked about how the torque varies through the train in section 5.3.

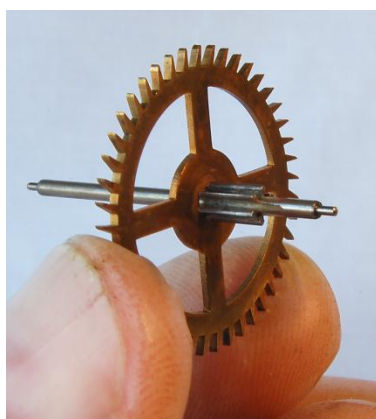

Figure 87 – escape wheel and pinion



Figure 88 – tooth form of escape wheel

The **escape wheel and pinion** is shown in Figure 87. It is made in much the same way as the rest of the wheels, except that the shape of the escape wheel teeth – Figure 88 – is completely different because the teeth engage with the pallets, rather

than driving another pinion. We will look in detail at the recoil escapement in Lesson 3.

6.11 Centre wheel and hand setting

We have left the **centre wheel and pinion** until last because it is the most complicated. If you remember back to section 5.7 you will recall that the hand setting mechanism requires a friction drive between the train and the motion work. The centre arbor assembly incorporates this clutch. The wheel and pinion form part of the train and thus *cannot* be turned by hand, but the centre arbor – which carries the minute hand – *can* rotate with respect to the minute wheel and pinion, thus letting us turn the hands to the correct time.

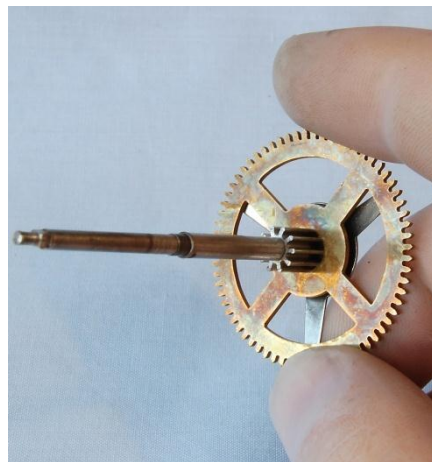

Figure 89 – centre arbor assembly



Figure 90 – the components of the friction drive

We call it the “centre arbor assembly” because it is made of several parts. In Figure 89, it looks much like any other wheel in the train, although the extended arbor to carry the minute hand is obvious. However, there is one major difference: the wheel and pinion are not solidly connected to the arbor, as with all the other wheels. In fact, without the friction drive assembly – Figure 90 – they would spin freely on the arbor.

All will become clear when we dismantle it. In Figure 91, we have removed the brass pin and released the three-legged friction spring.



Figure 91 – three-legged friction spring

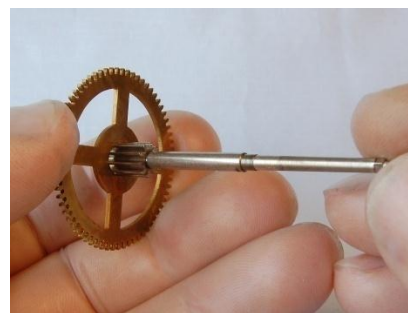

Figure 92 – centre arbor in the centre pinion

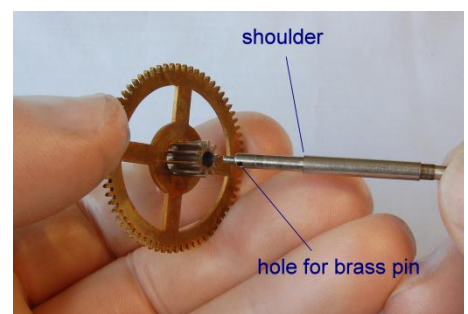

Figure 93 – centre arbor withdrawn from centre pinion

As you can see from Figure 92 and Figure 93, the centre wheel/pinion assembly is free to rotate on the centre arbor, but is “pinched” between the shoulder and the brass pin by the friction spring. Under normal running there is enough friction at the shoulder and the pin to turn the arbor along with the wheel/pinion assembly. However, when the arbor is forcibly rotated by setting the minute hand, slippage occurs at the shoulder and between the brass pin and the friction spring. The strength of the friction spring determines how much force is required to set the minute hand.

There are other friction drive arrangements used on older clocks – we will look at some of these in Lesson 2.

6.12 The frame – plates and pillars, bridges and cocks



Figure 96 – roller sinker

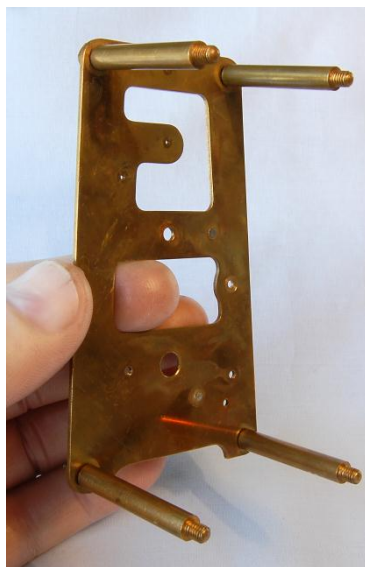

Figure 94 – front plate with pillars



Figure 95 – back plate

Virtually all clocks use brass plates and pillars. The pillars separate the two plates, and provide some rigidity between them. It is common to find large voids in one or both plates – it helps save brass and thus reduces manufacturing costs.



Figure 97 – oil sink

Most of the pivot holes have an oil sink – Figure 97. This acts as a reservoir for the lubricating oil. It is made with a circular chamfering tool called a **roller sinker** – Figure 96. If the oil sink is too shallow it will not hold sufficient oil. If it is too deep it reduces the thickness of the plate too much, allowing the pivot to wear the hole to an oval shape.

Cheap clocks with excessively thin plates do not have enough thickness for proper oil sinks. The lack of plate thickness, and the shortage of oil, leads to more rapid wear.

Oil sinks should have sharp shoulders at their outer edge. This helps prevent the oil spreading down the plate, away from where it is needed.



Figure 98 – pillars fastened to plates with nuts

The clock we are working on uses nuts to hold the pillars to both front and rear plates, as shown in Figure 98. Sometimes the pillar has a threaded hole and a screw passes through the plate into the pillar. The hole in the plate may be countersunk so that the screw head is flush with the plate.

Earlier clocks avoided using screw fasteners in this role. Figure 99 and Figure 100 show the arrangement from a 19th century wall clock. The pillars are riveted to the back plate. The job is so neat, only the slight difference in colour of the brass makes the riveting apparent.

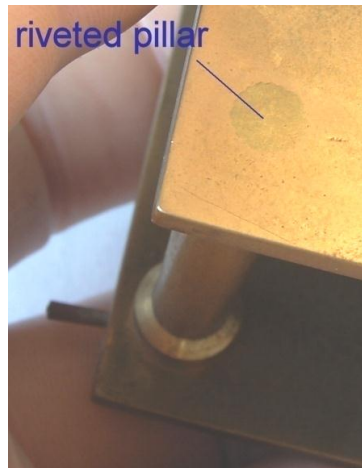

Figure 99 – pillar riveted to back plate

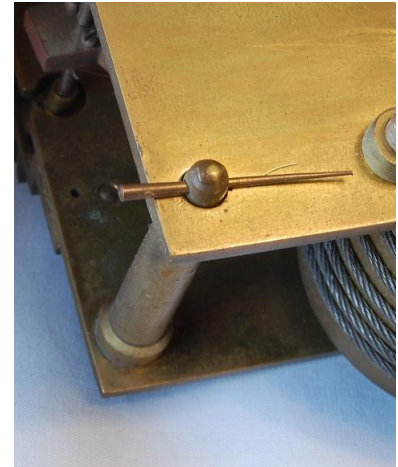

Figure 100 – front plate retained to pillar by tapered pin

The other end of the pillar has a hole drilled through, and the plate is firmly clamped to the pillar when a tapered pin is forced through the hole.

It has already been explained that there are often bridges and cocks which form part of the frame of a clock. The example of a bridge, although it is called a back cock, has already been mentioned during the dismantling of the Bentima clock. Another example of a bridge, the hour wheel bridge, will be provided together with an example of a cock.

The hour wheel bridge is generally found on longcase, dial and bracket clocks; it carries the pipe that provides a bearing for the hour wheel – Figure 101 .

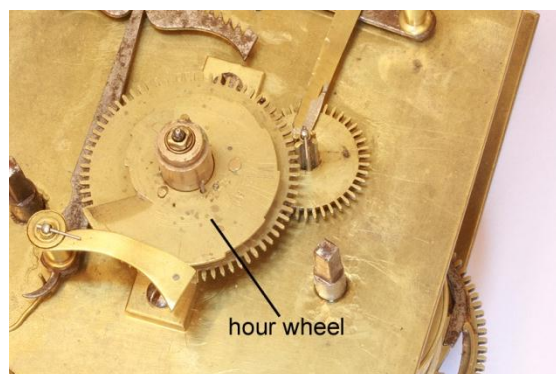

Figure 101 – long case hour wheel

When the hour wheel is removed the hour wheel bridge can be seen more clearly, Figure 102.

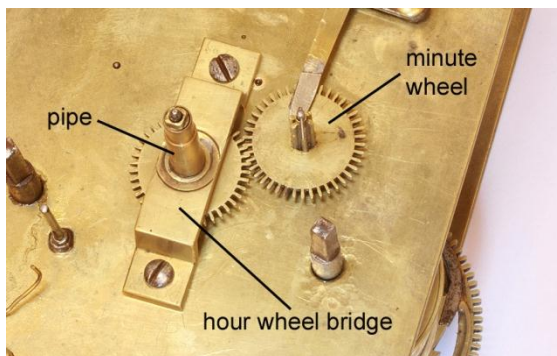

Figure 102 – longcase hour wheel bridge

The pipe forms the bearing for the hour wheel. The hour wheel bridge straddles the cannon wheel. The cannon wheel pipe and the centre arbor protrude through the pipe on the hour wheel bridge. The hour wheel bridge is secured by two screws and located with two steady pins which fit into holes in the front plate – Figure 103.

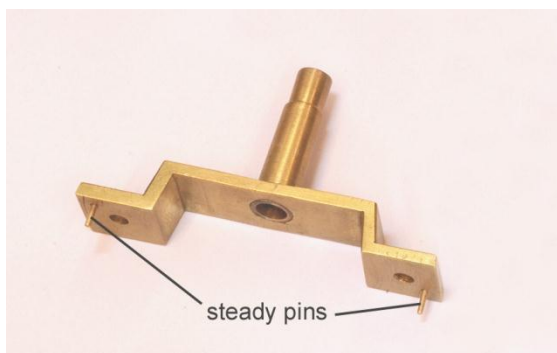

Figure 103 – steady pins to locate the hour wheel bridge

Figure 102 shows the minute wheel with its pinion; they rotate together on a post or stud projecting from the front plate. On many clocks a cock is used; the minute wheel and pinion turn with one pivot in the front plate and the other in a minute wheel cock – Figure 104.



Figure 104 – minute wheel cock

6.13 Summary

We have covered an enormous amount of ground in this section. Do not try to learn all the parts at this stage. Instead, refer back to it as we proceed through the course, and when you are revising for the examination. We will come across all these terms many more times as the course progresses.

NOTES

Workshop Skills

7 Health and Safety

There is a great deal of legislation relating to health and safety. In particular, if you are an employer, you should seek advice on your legal obligations to employees and customers. The BHI – the publisher of this course – is not allowed to give any legal advice.

However, for readers with a workshop just for their own use, we can point out some basic safety measures which you should consider.

7.1 Fire

Generally the risk of fire is small. However, some of the solvents you will be using are inflammable. You should do two things straight away:

- 1) buy a *fire extinguisher* and install it in your workshop
- 2) put a *smoke detector* just outside the entrance to the workshop (it might prove too sensitive if it is actually in the room)

7.2 Electrical

Normal domestic wiring standards are sufficient for a small clock and watch workshop. The biggest safety risk comes from old electrical equipment bought at clock fairs. Consider having it checked, and if necessary rewired, by a competent electrician. Basic domestic electrical safety practices should be observed.

7.3 Chemicals

You will be using:

- cleaning fluids
- solvents
- lubricants

Most of these are fairly benign, although solvents can be inflammable. Avoid storing large quantities of these in the workshop – consider keeping them outside in a shed or garage, and decanting small quantities into containers for use in the workshop. Cleaning fluids can give off harmful fumes, so use them in a well-ventilated place. Read and observe the warnings given on the container.

7.4 Eye protection

Buy some eye shields, and use them whenever you are using rotating machinery such as a grinder, drill or lathe.

7.5 Hand protection

If your skin is sensitive, use vinyl gloves. These will protect the skin against the chemicals you will be using in your workshop. We will be using these gloves anyway to protect clock parts from fingerprints after they have been cleaned, so put them on your shopping list now. Latex gloves offer a better grip on metal parts than vinyl, but be aware that some people are allergic to latex; secondly, latex goes sticky when in contact with some of the chemicals we will be using, which can result in marks resembling fingerprints being left on the parts.

The only other significant hazard to your hands comes from using a mainspring winding tool (we will be looking at these later in the course). A pair of tough leather gardening gloves is ideal protection.

7.6 Visitors

An injured visitor may have the right to sue you. If you are going to let visitors into your workshop, you should consider getting insurance to cover third party damages. This may be expensive. Alternatively, do not allow them into your workshop. "Enter at your own risk" signs may not carry much weight in law.

7.7 Common sense

The most important safety asset is common sense. Take a good look around your workshop. If something looks like it could be hazardous – sharp corners, objects teetering on high shelves – it probably will be. Put aside an hour to make your workshop as safe as possible.

8 Some common workshop tools

8.1 Screwdrivers

With the exception of a few 20th century mass-produced clocks, only slotted screws are used in horology.

Clock screwdrivers

Buy some good quality “flat” or “straight” tipped screwdrivers in a range of sizes. Worn tips are prone to riding out of screw heads and skidding across the surrounding surfaces, damaging the screw head itself and other parts of the clock. That is why you need good quality screwdrivers with hard, correctly formed tips. As the tips wear, reshape them with a file (the heat from grinding tends to soften the metal).

A Phillips N°1 and a Phillips N°2 screwdriver will take care of any cross-head screws you might find.

Watchmaker’s screwdrivers

Bruised screw heads indicate poor workmanship and will lose marks when you take your examinations. Manufacturers of high value movements expect that after a complete service the movement should be as new and not show any signs of work. The damage shown in Figure 105 is totally avoidable.

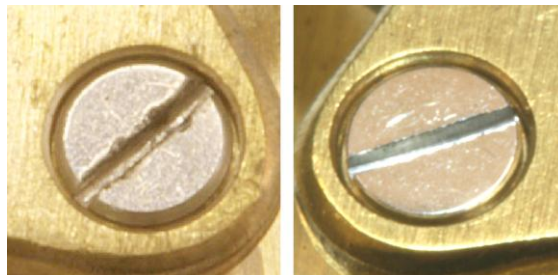

Figure 105 – damaged and undamaged screws

To minimize bruising of the screw slot and damage to components from the screwdriver slipping, the blade should fit the slot perfectly – Figure 106.

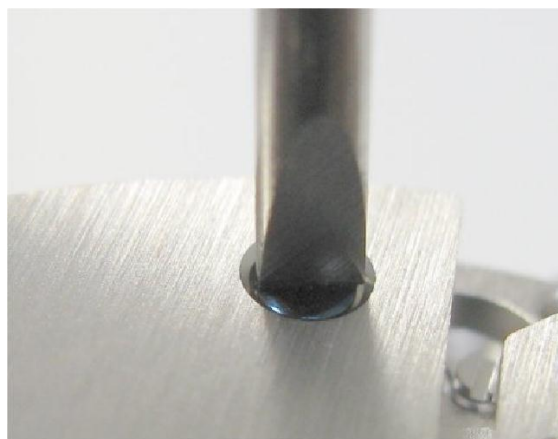

Figure 106 – the blade should fit the slot perfectly

If the blade is too wide it will scrape the plate causing unsightly damage; if it is too narrow the slot in the screw will be marked because pressure is concentrated on just a small area.

In addition to the blade fitting the length of the slot it should also fill the width of the slot.

Figure 107 shows the situations that can occur. In diagram A, the angle of the blade is too steep and too much downward pressure is needed to ensure the blade will not slip out of the slot and damage the plate; the blade will also bruise the edges of the screw slot.

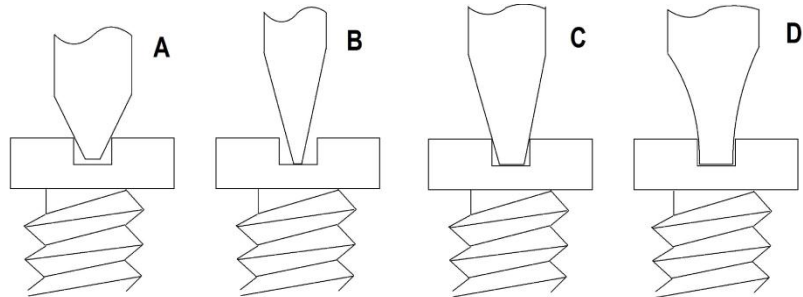

Figure 107 – the screwdriver blade must be the right angle and width for the slot

B shows the correct angle but the point is too sharp and not strong enough. This also could damage the slot, or the corners of the blade could break off or twist, again causing damage.

C is sharpened at a suitable angle and fits the screw slot well; it should cause minimum bruising to the screw head.

D is hollow ground and fits perfectly and should need very little downward pressure to turn the tightest of screws. There are tools available to hollow grind the blade so the fit in the screw slot is exact, thus avoiding bruising the edge of the screw slot. The sharpening stone is curved to form the hollow ground shape. (Bergeon ref. 6924; Horotec ref. MSA 01.502 – see Figure 108).



Figure 108 – Horotec screwdriver sharpener

Many watchmakers will have more than one set of screwdrivers available for different widths of screw slots. Some will have a set with beryllium bronze blades to reduce the risk of damage even further (beryllium bronze blades are available from some material dealers). These are especially useful when the same screw must be removed and refitted repeatedly, as was the case in Figure 105.

Very often watchmakers will put off sharpening their screwdrivers because this takes time, and time is money when you are self-employed, on a bonus or a piece-work contract. Most sharpen their screwdrivers in the traditional way, on an India stone, sometimes with the aid of a wheeled clamp to achieve symmetry and the desired angle – Figure 109. This approach is excellent but time consuming.



Figure 109 – using a screwdriver sharpening device

This process can be speeded up by using a 6inch, No. 4 cut, good quality pillar file. With practice, a well sharpened screwdriver blade can be achieved in seconds – Figure 110 and Figure 111. A fine oilstone will remove the file marks if required.

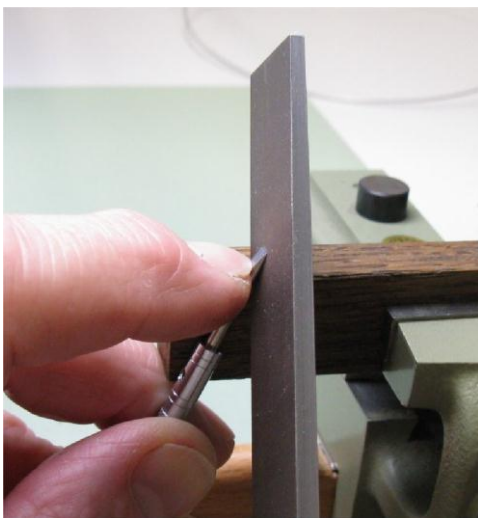

Figure 110 – sharpening the screwdriver on a file



Figure 111 – the blade can be sharpened in seconds

8.2 Tweezers

Tweezers are used for handling very small parts – especially watch parts.

As well as enabling tiny parts to be handled and manipulated, they also avoid finger marks getting onto the parts.

Tweezers come in a variety of sizes, shapes and materials.

Sizes

The size refers to the fineness of the tips. Very fine tips are needed for manipulating the smallest parts (such as watch screws). However, fine tips are delicate, being easily bent or distorted out of shape, so for larger parts you should use tweezers with broader tips. That is why you need a selection of sizes.

Unfortunately the manufacturers tend to use different numbering and lettering schemes for their tweezers. However, most watch tool suppliers give you an English description for each size, typically:

- broad
- medium
- fine
- very fine
- super fine

It is worth getting one of each, except for the broad tip, which does not have much use for watch work, although some people like them for handling clock parts.

Shapes

The tweezers used most of all in horology are straight with plain tips (you can get specialist tips for holding jewels, etc, but you will not need them for our purposes). The other shape you may need are curved tweezers, specifically made for manipulating balance springs.

Finally, you can get plastic tweezers with special spade tips, specifically for handling batteries.

Materials

Tweezers are available in steel, brass and plastic. You can also get metal tweezers (typically aluminium) with plastic or carbon fibre tips.

Steel tweezers are good all-rounders, but make quite sure you buy anti-magnetic ones. The big problem with steel tweezers is that they will mark delicate surfaces. Steel tweezers are electrically conductive so they must not be used for handling watch batteries because they will form a short circuit between the positive and negative poles.

Brass tweezers should be used for handling soft or delicate metal parts, such as watch plates. Not as hard as steel, they still make excellent all-round tweezers. As with steel, they conduct electricity so cannot be used to handle watch batteries.

Plastic tweezers are suitable for handling even the most delicate of parts, and are ideal for manipulating watch batteries. They lack rigidity, so the tips are prone to “crossing over”. They also lack strength at the tips, so they can easily be distorted or damaged.

Metal-bodied tweezers with plastic or carbon fibre tips have the rigidity of the steel or brass tweezers, but with non-marking, non-conductive tips.

Figure 112 shows a selection of tweezers.



Figure 112 – from top to bottom: medium steel, fine steel, spade-tipped plastic, medium brass, balance spring tweezers

We would advise buying the following to start with:

- Steel: medium, fine, very fine, super fine
- Brass: medium, fine
- Plastic: one pair with 3mm spade tips for handling batteries

Carbon fibre- or plastic-tipped tweezers can wait until you know you need them. You will need one or two pairs of balance spring tweezers, but not until Lesson 8, when we service a platform escapement.

Using and maintaining tweezers

The tips of tweezers will wear after a lot of use, or distort or bend if they are abused. Therefore it is often necessary to “dress” the tips to make them perfect.

You want the tips to be of equal width and thickness, with the correct degree of sharpness, and you want the inner surfaces to meet for a short distance behind the tip when the tweezers are closed with moderate pressure.

In particular, you do not want the tips to curl outwards when a part is held, as this can cause the held part to be ejected – Figure 113.

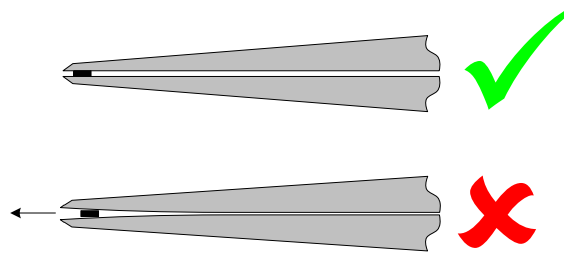

Figure 113 – the tips must be parallel when holding a part under moderate pressure

Before dressing, see if the tips need bending into position. Brass tweezers, in particular, are rather prone to getting bent tips.

Once any bending is done, use an Arkansas slip to dress the tips to perfection. Do not try to polish the inner, gripping surface: the finish from the Arkansas slip is just right to help the tweezers grip the part.

8.3 Vice

A vice is used to hold a part firmly while you work on it with other tools. For this course you need a vice with jaws 75mm wide, or wider (Figure 114). Bolt it rigidly to your bench, using large washers – or even a metal plate – to spread the load across the underside of the bench surface.

Most vices have serrated jaws to grip the work. Sometimes you will need to protect your work from the serrations using **clams**. Go to a large DIY store, model shop or metal supplier and buy a length of right-angled metal. Brass or steel is best, but aluminium will do. If possible get the type where the outer corner of the angle is sharp (i.e. the material has been extruded in this form) rather than blunt, which happens when the metal has been folded into a right angle.



Figure 114 – bench vice with clams

Clamp the length in the vice, protecting the outer surface with a piece of cardboard, and saw it off to the width of the jaws. The cardboard stops the serrations on the opposite jaw marking the working surface of the clam. Repeat to make the other clam. When you need to hold work without marking it, simply place the clams over the jaws and grip the work in the normal way.

We also recommend you buy a small, clamp-on table vice. These are excellent for holding small parts. The one shown in Figure 115 is adjustable to any angle and comes with removable plastic clams.



Figure 115 – clamp-on vice

8.4 Hacksaw

Hacksaws are designed to cut metal. A junior hacksaw (6" or 150mm blade) is always handy for small work, although most of the time we will be using a standard hacksaw with a 300mm blade. Figure 116 shows some examples. Buy one of each.

Hacksaw blades wear out, which is why the blades are replaceable. Poor quality blades are all too common in DIY shops, so make sure you buy ones from a well known brand. It is always worth spending the extra to get good blades.



Figure 116 – 300mm hacksaw, and two junior hacksaws

They come in different cuts from coarse to fine. A medium cut (around 20 teeth per inch) is best for our purposes. In general, a finer cut is better for cutting thin material, and a coarser cut for thick or soft material.

The hacksaw cuts on the forward stroke; blades should be fitted so that the teeth point forward. Blades can often be fitted into the hacksaw (but not the junior hacksaw) at right angles.



Figure 117 – from left to right: ball pein hammer; clock hammer; watch hammer; soft nosed hammer

8.5 Hammer

You need four hammers. Firstly, a **watch hammer**. They have a steel head with a round, flat face at one end. The opposite end tapers to a flat, blunt, chisel-like shape, known as the **pein**. The weight of the head should be around 1 to 2oz (30 to 60gm).

Next you need a **clock hammer**. This is the same shape as the watch hammer, but heavier.

Thirdly you need a **riveting hammer**, more commonly called a **ball pein hammer**. These have a smoothly domed face, instead of flat. For our purposes a fairly light one will be suitable – typically 4 to 8oz (100 to 200gm).

Finally, you should get a **soft-nosed hammer**. The type with a white nylon faces work well and will meet our requirements. Buy a light one: 8oz (200gm) is about right.

8.6 Files

There are two types of files you need to know about: *engineering files* and *precision files*. Engineering files are the type you see in every household toolbox, and can be bought cheaply from any tool shop or DIY store.

Precision files are sometimes called *Swiss files*, although that does not necessarily mean they are made in Switzerland. Precision files are made to a higher standard than engineering files. They also come in a wide range of shapes and sizes, some very specialised.

The coarseness of the cut is important. In general, coarser files (with a larger distance between the teeth) remove more material and leave a rougher finish. Also, coarser files are better on softer metals such as brass and aluminium, because smooth files will tend to clog. Table 1 compares the cuts of engineering files with precision files.

Precision file cut	Engineering file cut	Teeth per centimetre
00	Bastard	up to 17
0	Bastard/Second	
1	Second	18–22
2	Smooth	22–28
3	(no equivalent)	
4	(no equivalent)	
5	(no equivalent)	

Table 1 – precision and engineering files

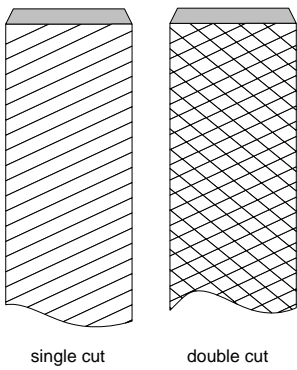

Figure 118 – single and double cut files

There are *single cut* and *double cut* files. Single cut files just have one row of teeth along the length. Double cut files have two rows of teeth set at an angle to each other – Figure 118.

We will now look at the most common types of precision file.

Hand file and pillar file:

The hand file is flat on both sides, untapered, and has one ‘safe’ (smooth) edge. It is the most commonly used, general purpose file in horological work. The pillar file is similar, but narrower so it can be used on more intricate pieces.



Figure 119 – hand file



Figure 120 – pillar file



Figure 121 – narrow pillar file

Taper flat (or warding):

This is similar to the hand file, but the blade is tapered so it can be used on small and restricted surfaces.



Figure 122 – taper flat (or warding) file

Three square:

This type has a triangular cross section and is tapered. It is useful for filing into tight corners.



Figure 123 – three square file

Half round:

The half round file is flat on one side, and rounded on the other (but not semi-circular). Both sides have teeth. The blade is tapered to improve access to small spaces. It is used for filing concave surfaces, and is good for filing into corners.



Figure 124 – half round file

Knife:

This is rather like a three square file, but the triangular cross-section is greatly elongated and narrowed into a knife blade shape. It is used for filing slots.



Figure 125 – knife file

Ridgeback or barrette (not shown)

This has a very flat triangular cross section, just the opposite of the knife. Teeth are provided on the base only – both top surfaces are safe (smooth).

Round or rat tail:

This type is used for enlarging holes, or “drawing” them (making them oval). The rat tail tapers to a fine point so it can enter a very small hole. It can also be used for rounding of corners.



Figure 126 – round or rat tail file

Square taper

This has a square section with all four sides cut. Like the round file, it is tapered to a fine point. It is useful for making square holes, sharpening up slots, etc.

**Crossing file:**

The crossing file has a tapered, oval cross section, and is used for crossing out wheels and similar jobs.

**Double ended pivot file and burnisher:**

As the name implies, this is two files in one, with the handle in the centre. There is a pivot file at one end, the teeth of which are extremely fine. At the other end is a smooth strip of steel, which is prepared by rubbing it on an abrasive before using it to burnish a pivot.



Slotting file:

This is used for cutting slots in screw heads. It is rather like a fine saw with teeth on both edges.

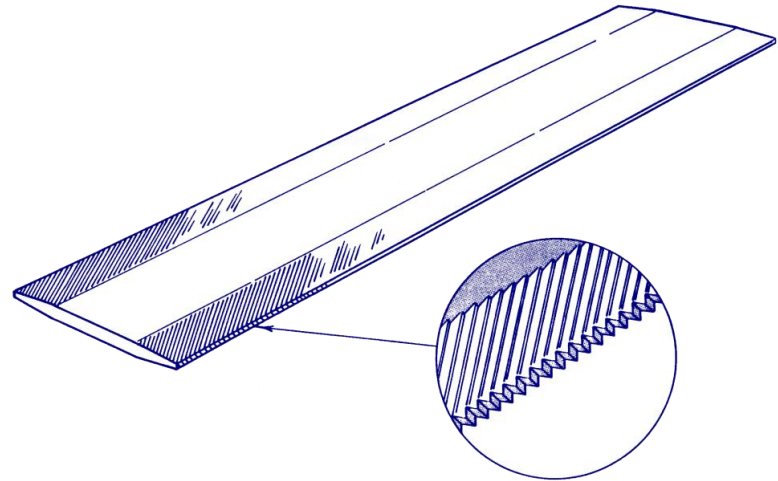

Figure 127 – slotting file

Needle files:

Needle files are smaller than engineering or precision files. Instead of a tang, the handle is formed as one piece with the blade. Sometimes the handle is round so it will fit into a pin vice or collet.

Needle files come in all sorts of shapes, including those listed above.

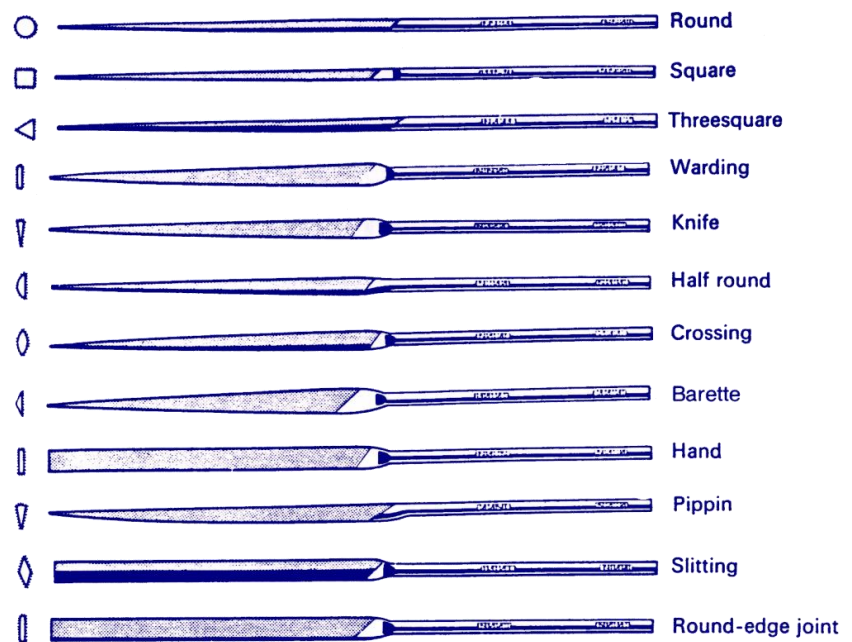

Figure 128 – needle files

Escapement files:

Escapement files are like needle files, only smaller still and they normally have square handles. They are used for filing the tiny parts of an escapement, and come in a great variety of shapes.

8.7 Care of files

Files are made from very hard steel, and the teeth will chip with careless handling. Do not throw them into a drawer with other tools.

Filing brass requires very sharp teeth for the best result. A file which has been dulled by filing steel will never cut brass quite as well. If you are concerned about this, consider putting aside brand new files solely for use on brass. When they eventually become worn, they can then be “demoted” for use on steel.

Files tend to clog with dirt and grease – clean them with white spirit or petrol.

Files can also become clogged with bits of metal – especially after filing something soft such as brass. Do not attempt to use the type of steel brush generally recommended for cleaning files it can easily damage a file, especially a fine file.

A brass wire brush is more acceptable but does not work as well. Better, take a piece of brass plate, file one edge sharp, and feed it between the teeth to push the swarf out. You can also buy special tools for cleaning files, although they are essentially a special type of steel wire brush, so should never be used on a good quality file.

To help prevent swarf clogging the file, rub a piece of soft chalk over it, making sure it goes to the root of the teeth. Be aware that this will make your workshop dusty.

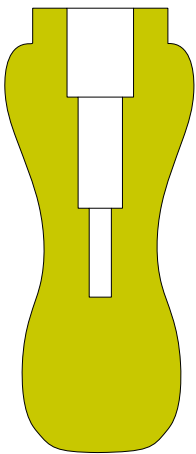

Figure 129 – drilling a file handle for a tang

8.8 File handles

Files with tangs are meant to have a handle fitted. Never use such a file without a handle, because if it catches on the work you can drive the tang into the palm of your hand.

You can buy file handles from hardware shops. Make a roughly tapered hole down the handle by using three drills of different sizes, driving them to the appropriate depth. Figure 129 gives you the idea, exaggerated for effect.

Make sure the hole is deep enough to swallow the whole tang. Ensure the ferrule is fitted around the open end of the handle. Push the tang firmly into the hole, and then hit the base of the handle smartly onto a hard surface, embedding the file tang firmly into the handle. You might need to experiment a couple of times with the hole sizes.

To remove the handle, grip the edge of the file in a vice, making sure the jaws grip an uncut area, and then give the ferrule a sharp tap with a hammer.

8.9 What files to buy

By now you are probably feeling rather overwhelmed at the number of files you might need, and the costs involved, but there is no need to worry.

For now, you should buy four good quality engineering files. They may be available from a DIY shop or otherwise you will need to approach a horological tool dealer or engineering supplier. Two “cuts” will be required: a coarse file to remove metal quickly; and a finer file for finishing. If you can afford it, “precision” files are a better alternative to the finer engineering files. The table below gives the details.

Shape of file	Coarse	Fine, either Engineer’s or Precision Files	
	Engineer’s File 150mm (6in) long	Engineer’s File 100mm (4in) long	Precision File 100mm (4in) long
Hand	Second Cut	Smooth	Cut 4
Half Round	Second Cut	Smooth	Cut 4

The hand file is probably the single most important general purpose engineering file, because it has one safe edge, and the parallel cross-section makes it easy to use. The next most important is the half-round file. If you are purchasing precision files then Vallorbe is a well respected maker.

Another very useful file for internal curves is the “crossing” file; it will only be available as a precision file. A fine crossing file (cut 4) approximately 100mm (4ins) long will be useful for finishing the crossings on wheels. That takes care of the full sized files.

Finally, needle files are necessary to complete your collection. There are packs of needle files that can be bought very cheaply from tool shops, modelling shops or DIY stores; these will contain almost all the special shapes we have described earlier.

The files in these packs usually have quite a coarse cut and it will be useful to buy three good quality needle files (such as Vallorbe). For these individual files, the best shapes to buy are barrette, square and crossing, and they should be cut 4. Keep these files for use on brass until they lose their sharpness and then they can be relegated for steel and new files purchased for brass. The needle files should be ground, as shown in Figure 130, to help you file sharp internal corners. When grinding the needle files, take great care to ensure that the file does not overheat; careless grinding will draw the temper of the file making it soft and of little use.

Diamond coated needle files are readily available from Clock Fairs and material dealers. They are suitable for filing hardened steel but many are of a coarse cut which requires careful finishing. Fine diamond needle files can be very useful for making adjustments to clock escapements.

As your work proceeds you will find that more files will be required but this selection will enable you to commence on the practical exercises in the course as well as making some clock components.

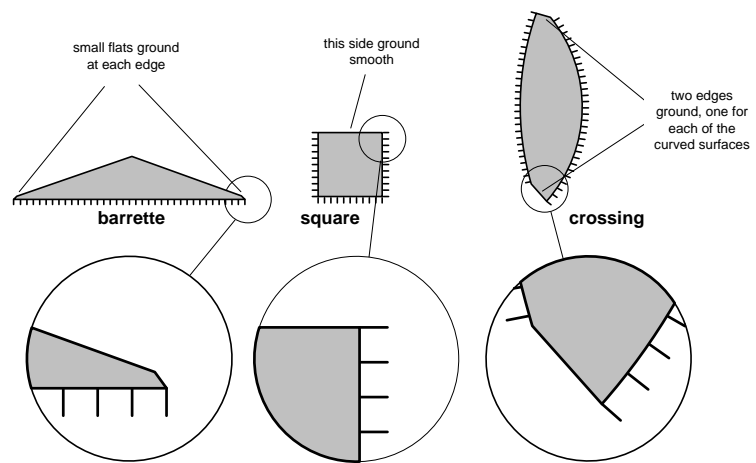

Figure 130 – grinding as shown provides a "safe" edge and ensures the teeth go right to the edge

8.10 Broaches

There are two types of broach: the cutting broach; and the smoothing broach. Both are superficially similar in appearance – a long, thin, spike-like blade, either with a tang or mounted in a handle. The handles are often too small to provide a good grip. To improve the grip, small broaches can be held in a pin chuck, larger ones can be fitted to file handles.

Cutting broach

The cutting broach is used to enlarge an existing hole. It cannot make a hole itself. Is used to open a hole to a precise diameter.

It has a pentagonal (five-sided) cross section, and is gently tapered along its length. The blade is hardened and tempered steel. The corners of the pentagon form the cutting edges. The broach is introduced into the hole until the cutting edges contact the walls of the hole. The broach is then turned between the finger and thumb with gentle pressure towards the hole. The cutting edges remove brass from the hole, increasing its diameter. As the diameter increases, the broach naturally enters the hole further.

The pentagonal form of the cutting broach means that the hole remains exactly circular as it is opened.

It is not normally necessary to use oil with a cutting broach.

There are three points to emphasise:

1. the broach must be held at right angles to the plate, in both vertical and horizontal planes, and this requires some skill
2. due to the gentle taper, the resultant hole is tapered, too, although this can be mitigated to some extent by using the broach from both sides of the plate
3. cutting broaches only work in brass or other soft metals, not steel

We will have lots of practice with cutting broaches as we proceed through the course.

Smoothing broach

The smoothing broach resembles the cutting broach, except that it has a round section (it is still tapered along its length). The surface of the broach has a smooth, satin-like finish which is prepared by rubbing it on a fine abrasive.

It is used after a cutting broach, and when pushed gently into the hole and spun, smooths and work hardens the inner surface of the hole.

Oil applied to the broach helps prevent any tearing of the brass as the steel surface of the broach rubs over it.

The smoothing broach *displaces* the brass (rather than cuts or abrades it) to form the smooth surface. Therefore a small burr around the edge of the hole is quite normal and should be removed afterwards.



Figure 131 – smoothing broach (left), and cutting broach

8.11 Thread cutting

We will look at three ways of cutting threads: tap; die, and screw plate. The screw plate is really just a die in another form.



Figure 132 – tap wrench and tap

Tap

A tap is used to cut an internal thread, like the thread in a nut. It is made from hard steel, and has a sharp thread around the outside which cuts the thread in the receiving hole. Three flutes run down the length of the tap to provide the cutting edges and remove the swarf.

Taps are normally held in a *tap wrench* which allows the tap to be turned by hand.

Taper taps are tapered towards the end, so that the first few threads they cut are shallow, making it easy for the tap to enter the hole and start cutting. If the hole is open at the other end, a taper tap can be screwed right through, making the thread in one operation. If the hole is closed at the far end (“blind”), then the taper tap must be followed by a *second tap* (slightly less tapered) and finally a *plug* or *bottoming tap*. The plug tap has no taper and thus will form a full depth thread right to the bottom of a blind hole.

When using a tap, it must be held exactly perpendicular to the surface, so that the threaded hole is true. The tap is turned forwards and backwards, cutting the thread a little at a time. The backward rotation – of about half a turn – breaks the newly cut swarf so it does not built up and jam the tap, leading to breakage.

Tapping requires some practice, as taps snap quite easily and the correct back-and-forth action is required to get a good finish on the thread.

It is important that the hole is exactly the right size for the required thread. Tables are available giving the correct size pilot hole to drill for any given thread. It is not really practicable to tap hardened steel, because the tap will almost certainly break. Steel should be brought to its final hardness after it has been tapped.

Special thread-cutting lubricant is available which prevents micro-welding and improves the finish when threading steel.

Die

A die is used to cut an external thread onto a rod, like the thread on a bolt. It is a round steel block with an internal hole threaded to the required size and pitch. Three or four flutes are cut into the internal wall to provide the cutting edges and allow the swarf to fall free.

Dies are normally held in a die stock, which allows it to be handled and turned easily.

On one side of the die the hole is slightly chamfered. This makes the first few threads shallow and allows the die to get started properly. When the required length has been cut, the die is turned over so the side without the chamfer leads, cutting a full depth thread for the entire length. Some dies are chamfered on both sides, so cannot be used in this way.



Figure 133 – die stock and two dies

As with a tap, the die must be held perpendicular to the rod being cut. Unlike a tap, the die is quite robust. However, it should not be forced to cut hardened steel (anneal it first), nor should it be forced to cut a rod of the wrong starting diameter, as it will spoil the finish and form of the thread. A chamfer should be formed on the end of the material to help start the thread.

The exact diameter of the rod is important. Tables are available which give the required diameter of rod for a given thread.

Screw plate

The screw plate is really just a number of dies all formed in one plate. They are normally used to make very small screws, such as those used in watches. Some have holes with a sharp internal thread, and a slot leading from the holes to clear the swarf. Others work by “burring” or “flowing” the metal into a thread, and do not have swarf clearance holes. As with taps and dies, the material to be threaded must be considerably softer than the screw plate.

Figure 134 shows a typical screw plate with both “burring” and “cutting” holes, along with three watch-sized taps. A British pound coin is shown for scale, emphasising the tiny size of the taps.

Just the beginning...

Whole books have been written on the subject of taps, dies and thread cutting. The above is merely an overview to make you aware of how it is done.



Figure 134 – screw plate and three watch-sized taps, with a pound coin for scale

8.12 Abrasives

Abrasives are used for imparting a finish to a piece of metal. We will be using abrasives in two different roles:

1. sharpening and smoothing tools
2. achieving a suitable finish on clock and watch parts

The finish we apply to parts of clocks and watches has two purposes: first, to make the parts look nice; second, to allow parts to operate against another without too much friction.

India stone:

This is the common name for a tool sharpening stone made from aluminium oxide. Sometimes they are double sided, with one side coarser than the other (the orange side being the smoother of the two). It is suitable for sharpening all grades of steel tool, but not tungsten carbide. Brass clogs the stone. It imparts a good, smooth finish to steel edges and surfaces. Oil should be used to prevent clogging.



Figure 135 – India (aluminium oxide) stone

Arkansas stone:

This is a natural stone which is cut into slabs and into rods with rectangular, triangular, knife or circular cross section. It will sharpen all grades of steel, but not tungsten carbide. Brass clogs the stone. It imparts a finer finish than an India stone. Arkansas stones can also be used in the preparation of pivots and other steel clock and watch parts (we will cover this later in the course). The stone should be wetted with oil.

Water of Ayr stone:

This is a soft, abrasive stone which must be used thoroughly wetted with water. It is excellent for removing marks from brass clock plates. It cannot be used on steel or tungsten carbide.



Figure 136 – assorted Arkansas stones, and a Water of Ayr stone

Diamond slips:

Diamond slips come in a variety of shapes and grades (coarseness). They sharpen steel tools very quickly, but the finish is not as good as an India stone unless a very fine grade is used. A good approach is to bring the tool edge to shape on a diamond slip, and then do the final smoothing with an India stone. Diamond slips should be thoroughly wetted with water (*not* oil). They are the only type of abrasive to sharpen tungsten carbide tools. Brass clogs a diamond slip.



Figure 137 – an assortment of diamond slips

Abrasive paper:

“Wet and dry” abrasive paper sheets are widely used in horology. They are available in a range of grades. The coarsest grade used in horology is 120 grit, and the finest generally available is 1000 or 1200 grit.

Also available are a range of micromesh papers from 3M, with grit sizes down to a few microns.

Abrasive papers can be used on brass or steel, but do not work on tungsten carbide. The wide range of grades means they can impart a range of finishes, and they are extremely versatile. Every horologist should have a range in stock. A good start is to stock 400, 600 and 1200 grit sheets.

Although “wet and dry” sheets can be used dry, it is almost always better to use them wet, or even under water. This greatly reduces clogging (which can cause

scratches) and improves the quality of the finish. Detergent can be added to the water to improve its wetting action and reduce clogging further.

You can also buy *emery cloth* (or *emery paper*, which is not waterproof). Emery cloth is a cloth backing with an abrasive grit stuck to it. It is not as suitable for horological work as wet and dry paper, because it is much more prone to shedding the abrasive, which causes scratches on the work.



Figure 138 – "wet and dry" abrasive paper

Buff sticks:

These are flat sticks of wood with abrasive paper glued to them. You can buy them, but it is better to make them yourself. In many respects they are like a file, except the surface abrades rather than cuts, and you can choose a much wider range of grades.

For finer work, abrasive paper can be stuck to pieces of metal with double sided Sellotape (a piece of metal shaped like a barrette needle file is ideal).

They are very useful for final finishing of parts, as the wood/metal ensures the abrasive surface is dead flat and rigid.

Wire wool:

Wire wool is commonly available in a variety of grades. It is excellent for removing rust from steel parts.

Clock Servicing Skills

Content begins in Lesson 3

Watch Servicing Skills

Content begins in Lesson 3

Practical Exercise

9 Introduction to Practical Exercises

The lessons in the Practical Watch Section of this Course have been designed, first of all to teach the correct way in which to carry out the fundamental operations which are the foundation of all practical horological work, and then to apply the instruction given.

We realise full well that it is a very difficult task to teach by correspondence all that is necessary for the acquisition of practical ability. We cannot hope to succeed without your very close co-operation.

Each part of the work covers a definite step. You are expected to do this work exactly as instructed — to do no less and no more. Particularly no more, since there is a definite object in each step and if you try to go too quickly or to employ methods other than those described, confusion will result and progress will be erratic. If you were attending classes or receiving personal tuition, you would carry out your instructor's directions exactly — and this is exactly what we want you to do now. Metaphorically speaking, we shall always be at your side. After some stages of the work have been completed, the parts are to be sent to the British Horological Institute for examination and constructive criticism. While these parts are out of your possession more work will have been set and you will be proceeding with the next stage; in this way you will never be left with nothing to do — the work will proceed without interruption.

It is, of course, absolutely essential that every part submitted to the Institute should be carefully marked with your name, address and DLC student number, so that it can easily be identified. The best method is to pack the parts in a suitable box, with a label inside bearing your name, address and DLC student number in block letters. Stick-on labels, and particularly adhesive tape, should not be used, as they tend to destroy the finish. Whenever possible, your DLC student number should be scratched on the actual work, in such a position that it will not spoil any finished surface that will be visible when the particular piece is in use. Instructions for doing this will be given at the appropriate times.

The Tutors will find it difficult to identify your work if it is not properly labelled — this is bound to cause considerable delay. Your effort will be wasted if any parts are damaged or go astray in the post due to inadequate packing.

It is also important to understand that if, for one reason or another, you have difficulty in completing the set work within the normal time; you should not try to hurry. Our aim is to teach you to do the work as well as possible; nobody can succeed in doing this if the work is rushed. Complete one lesson at a time before commencing the next; if necessary, the Tutors would far rather see you take months instead of weeks to complete each stage. You should complete each stage in your own time and to the best standard you can achieve, instead of trying to follow a strict timetable.

If, for some reason, your work is not up to the standard required, and it cannot be corrected, you will be asked to repeat it, so that you will be proficient at each particular stage before passing on to the next.

9.1 Method

As in other walks of life, there are many ways of doing most jobs connected with our craft. Many eminent craftsmen argue that one method is better than another; some prefer one, some another. The method described in this Course for executing each particular piece of work has been found to be satisfactory, as the result of the experience of many skilled horologists over a long period of time. The instructions given must be followed exactly.

There is one fact that must never be lost sight of. Bad habits are easily formed and are hard to break. This applies with special significance to practical work. If for example, you start to file in an unorthodox way, you will find it very difficult to file flat ever afterwards — and the ability to file flat is the basis of all good filing.

In order that nothing shall go to waste, the set work covers the making of tools and equipment which will be of life-long service in the workshop.

The work to be done is of a simple nature, but this does not mean that it is easy to do. Far from it! From beginning to end it will require a lot of thought and great concentration. Because it is simple does not imply that it can be done in a haphazard fashion. As stated previously, each lesson is meant to cover a definite stage; when each of these stages is mastered you will be well on the way to becoming a good craftsman.

Practice, and lots of it, is the essence of all practical work. Thus while we shall teach you the proper methods, it is up to you to practise them at every possible opportunity.

Before starting on any of the practical set work, first of all read the lesson right through very carefully, and thus get a picture in your mind of exactly what is required, and how it is to be done.

10 The fundamentals of practical work

When confronted with any problem it is always a good plan to analyse it; to reduce it to its simplest form. If this maxim is applied to horological work, many a task that appears at first sight to be extremely difficult will be found to be nothing like as hard as originally imagined. In this way, all horological practical work will be found to require one or more of four fundamental operations, i.e.

- Filing
- Drilling
- Turning
- Finishing

Each of these basic operations has many facets, as will be apparent as experience is gained.

The object of the first lesson is to practise and gain proficiency in filing. This will be followed by work involving drilling, turning, tapping, screw making, etc. As you proceed and acquire dexterity, you will be making small tools and pieces of workshop equipment. In this way, nothing you do will be wasted effort in any sense of the word.

11 Hand removing levers

The first practical work to be carried out is a simple exercise in filing flat and square, which will produce a pair of hand removing levers, as shown in Figure 139 overleaf.

Hand removing levers are miniature crow-bars and are used in pairs to lever off the hands of a watch movement. They can be made in numerous sizes to suit movements of different types. We shall start by making a pair suitable for removing the hands of a pocket watch.

11.1 Material required

Silver steel rod 5mm diameter x 150mm long.

11.2 Operations

- 1) Cut the rod into two lengths, each 75mm long, to make identical levers. The same work is to be carried out on each of these two lengths.
- 2) File both ends flat and square.
- 3) File a small bevel, or chamfer, at one end, all round the rod. To do this, clamp up a block of wood in the vice, with the top protruding above the jaws. Hold the rod against the block at an angle of about 45° and file a small flat at this angle. Then turn the rod through about an eighth of the circle and file another similar flat. Continue by turning the rod slightly and filing another flat after each movement. The result will be several flats, which should all be at the same angle. Now with a combined filing and turning action blend all the flats into a smooth bevelled surface, which should be about 0.8 from the extremity along the rod and the same distance towards the centre of the end of the rod.

- 4) The next operation is to taper the other end of the rod, making two flat surfaces coming to an edge at the extremity of the rod, at the full diameter, rather like the blade of a screwdriver, as shown in Figure 139. From the end opposite the bevel, measure off and mark a distance of 30mm. Clamp up the rod in the vice, using brass or copper clams to protect the surface, with the mark at 30mm from the end level with the top of the jaws and at such an angle that half the diameter of the extremity of the rod will also be level with the top of the jaws. Now, file flat to produce the first tapered surface. Use a medium cut file.

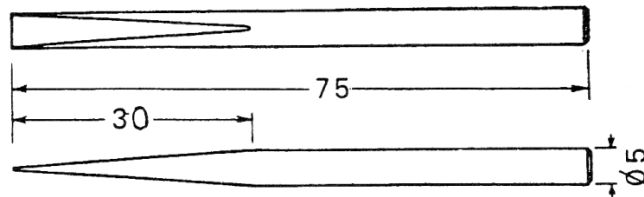

Figure 139 – Hand removing levers

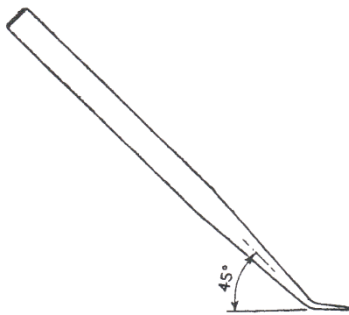

Figure 140 – curve end

- 5) Turn the rod through 180° and clamp up again, and file the second tapered surface. Check, while filing the second tapered surface, that the two flats are strictly opposite each other.
- 6) Finish both flats with a fine cut file, making sure that the ends meet properly to form a straight edge at the full diameter of the rod. Complete this stage by draw filing.
- 7) Trim the ends perfectly flat and square.
- 8) Polish the flats with fine emery cloth, imparting a straight grain finish.
- 9) The next operation is to curve the extremity to give the lever a crow-bar effect, as show in Figure 140. To do this, clamp up the lever in the vice against a short length of 10mm diameter brass rod, with the tip of the lever below the centre of the brass rod. Make sure that the brass rod is strictly horizontal, or parallel to the jaws of the vice, and that the lever stands perfectly vertical. Now bend the lever to an angle of 45°, so that its tip will be curved to conform to the circumference of the brass rod, as shown in Figure 141.
- 10) With a fine-cut rat tail, or round, needle file make a small semi-circular groove about 0.4mm deep centrally in the curved tip of the lever, as shown in Figure 142. Be careful to remove any burrs by polishing with fine wet and dry paper (1200 grade).
- 11) Re-polish the whole of the lever with fine wet and dry paper (1200 grade).
- 12) Make both levers exactly alike.

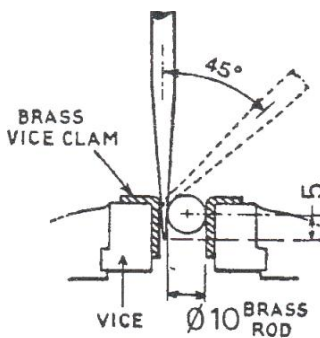

Figure 141 – bend in vice

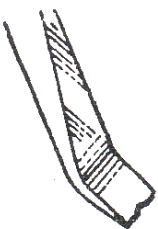

Figure 142 – small nick at extremity

Written Exercise

Please answer each of the following questions. For the majority only a short answer is required: one or two sentences.

1. What are the most accurate timekeepers available today? Give the name of the oscillator and their accuracy.
2. Which came first – the lantern clock or the longcase clock? How are they related?
3. Why do some clocks have repeating mechanisms, which make them strike the time on demand? How are they operated?
4. Explain the difference between an English Dial clock and a Drop dial clock.
5. Why was the balance adopted for portable clocks?
6. Explain an easy way to spot a quartz movement without looking in the back.
7. What is the semi-circular weight for in the back of an automatic watch?
8. Why were LED quartz watches abandoned and replaced with LCD watches?
9. Explain the difference between a resonant and a non-resonant oscillator.
10. A watch ticks five times per second. What is its frequency in Hertz? What is its frequency in BPH?
11. All mechanical clocks store energy to provide the motive power in a spring or weight. Why is it important to store the energy?
12. Describe the basic divisions of the mechanical movement.
13. Explain the role of the motion work.
14. Why is the hour wheel so-called?
15. What is the minute hand mounted on?
16. What supports the weight of the pendulum?
17. Explain the difference between a plate, bridge and cock.
18. What do the pallets engage with?
19. What is the purpose of the ratchet wheel in the winding mechanism?
20. In an 8-day clock, the third wheel is the fourth wheel in the train (starting from the great wheel). Why is it so called?

21. How are pivots prepared for a long service life?
22. Where is the hand-setting mechanism? How does it allow the hands to be set?
23. Name three ways in which plates are fastened to pillars.
24. When should eye protection be used?
25. What should you consider before letting visitors into your workshop?
26. Explain the difference between engineering files and precision files.
27. Why must a file with tang never be used without a handle?
28. Explain the difference between a cutting broach and a smoothing broach. Summarise how they are used.
29. What abrasive is required to sharpen tungsten carbide tools?
30. What must you be wary of when using emery cloth?

END